

## Table of Content

Alilo	2	Kriste Aghdga	25
Alilo	3	Lale	26
Aragvis Piruli	4	Lazare	27
Batonebis Nanina	5	Lazhgvash	28
Batonebis Simghera	6	Lile	29
Batonebo	7	Maspindzelsa	30
Batonebo	8	Misdevs Mela Lomsa	31
Deda Mogikvdesa	9	Mze Shina	32
Deli Deli	10	Nana	33
Dghres Saghvtoman Madlman	11	Nana	34
Didavoi Nana	12	Nanina	35
Dideba	13	Nani Nada Batonebo	36
Erekles Mravalzhamier	14	Ortameluri	37
Es Akvani Kharatuli	15	Samshoblo	38
Ghighini	16	Sedeko	39
Ghmerti Upali	17	Shen Khar Venakhi	40
Heyamoli	18	Sisatura	41
Ia Patonepi	19	Thebrone	42
Iavnana	20	Tsmindao Ghmerto	43
Ima Mtaze	21	Va Giorko	44
Jvaris Tsinasa	22	Varado	45
Jvarsa Shensa	23	Zruni Glola	46

### Alilo (12TET)

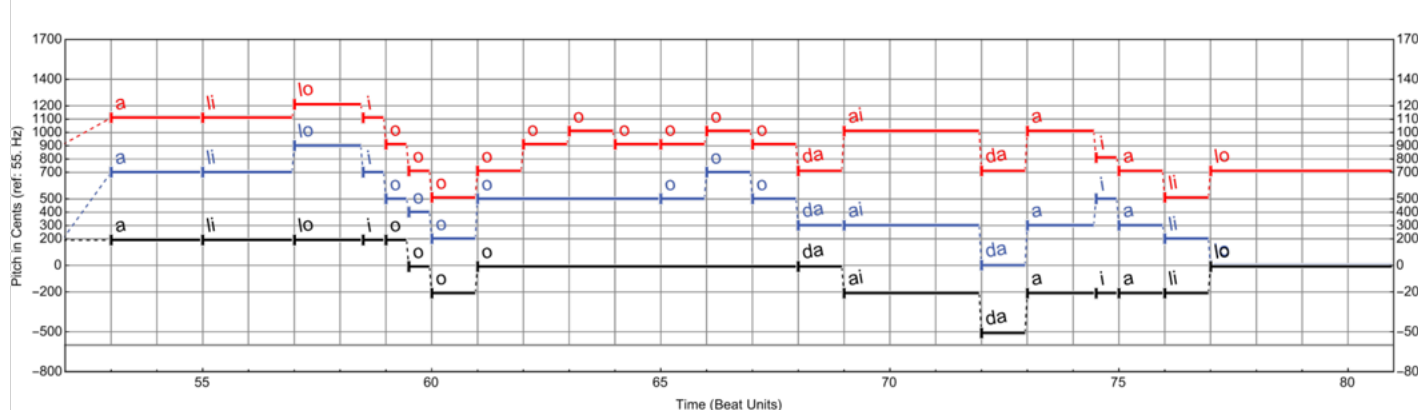
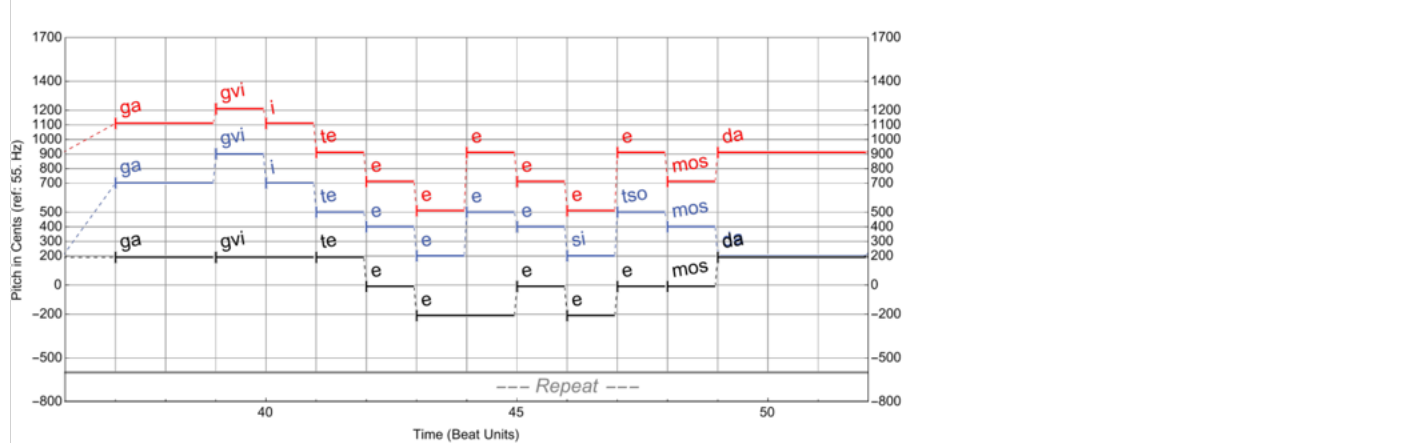
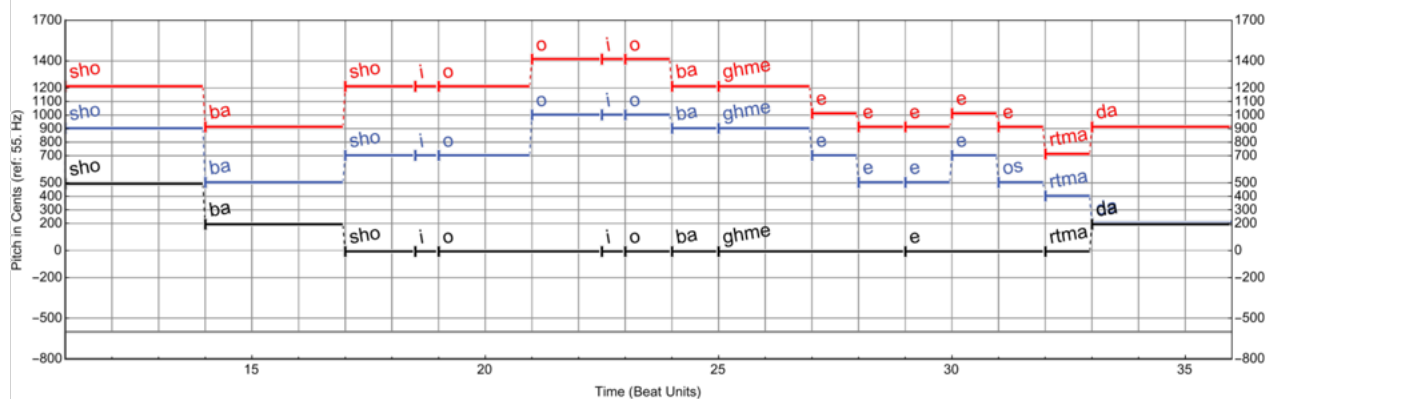
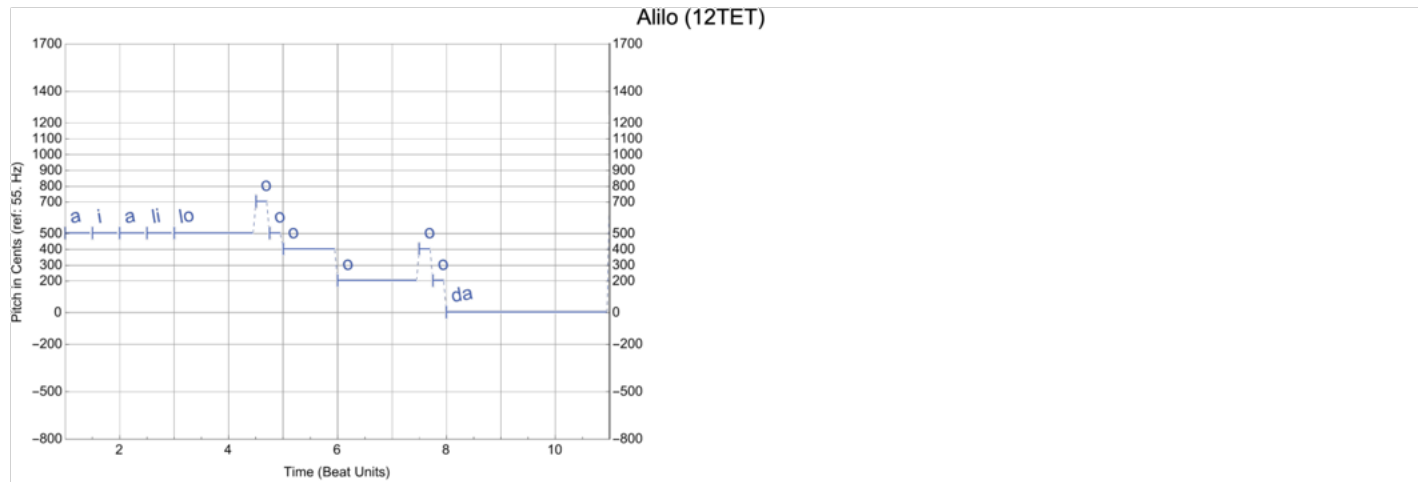

1. a i a li lo o o o o da

- sho ba sho i o o i o ba ghme e e e e e rtma da ga gvi i te e e e e e mos da a li lo i o o o o o da ai da a i a li lo
2. sho ba sho i o o i o ba a a a a a khal tse tse li i tsa a a a a a di da a li lo i o o o o o da ai da a i a li lo
3. ots da o i o i o tsa da u u u u tsa da am tve e sa a a a a a o da kri ste i i i i i i i shva ai da a i a li lo
4. i ne i i i i i ne bo o o o o os ghmer tma ak tve e ni i i i i si tso khle da a li lo i o o o o o da ai da a i a li lo
5. sho ba sho i o o i o ba ghme e rtma da ga gvi te e e e e e mos da a li lo i o o o o o da ai da a i a li lo.



This work is licensed under a Creative Commons Attribution International 4.0 License. © 2024 Copyright held by Frank Scherbaum.

### Alilo (12TET)

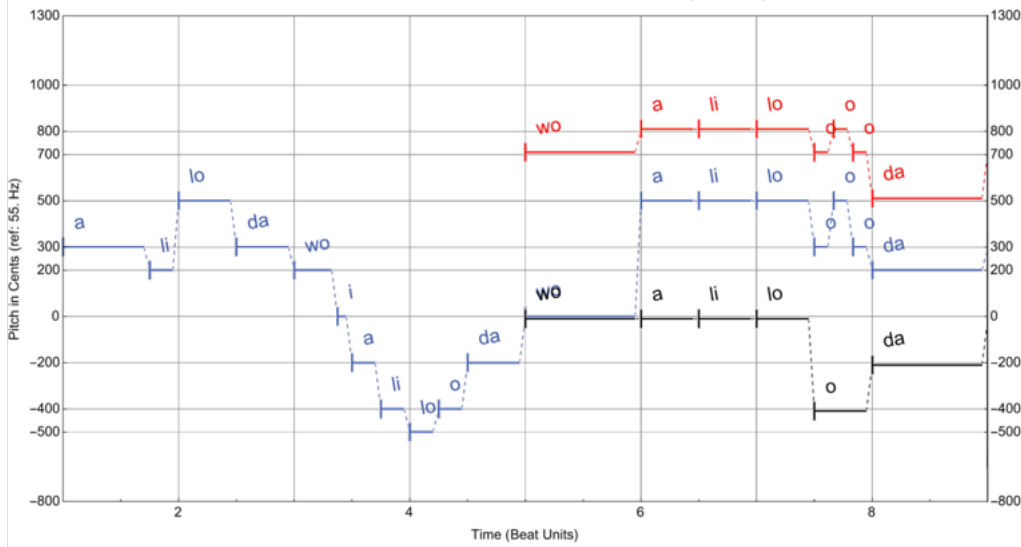

1. - .

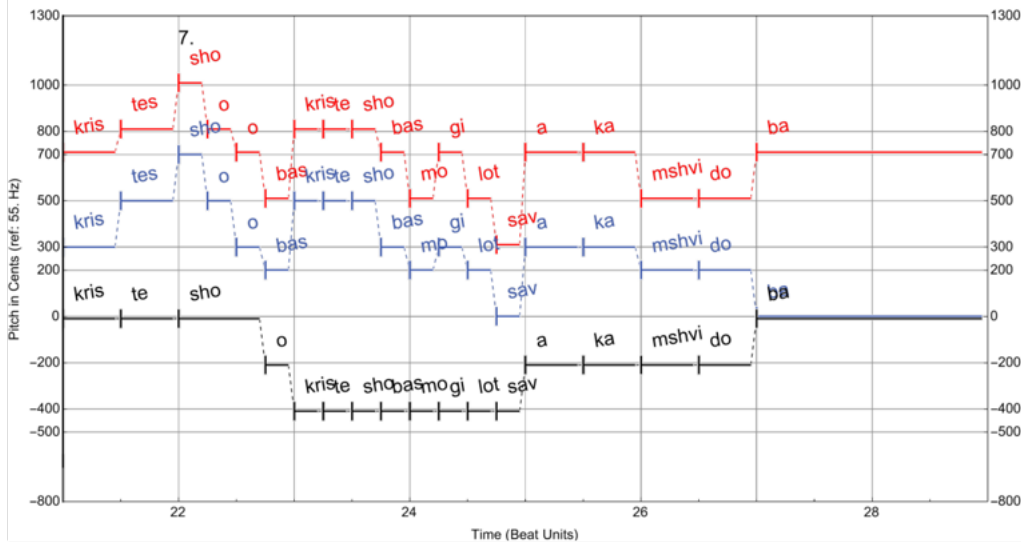
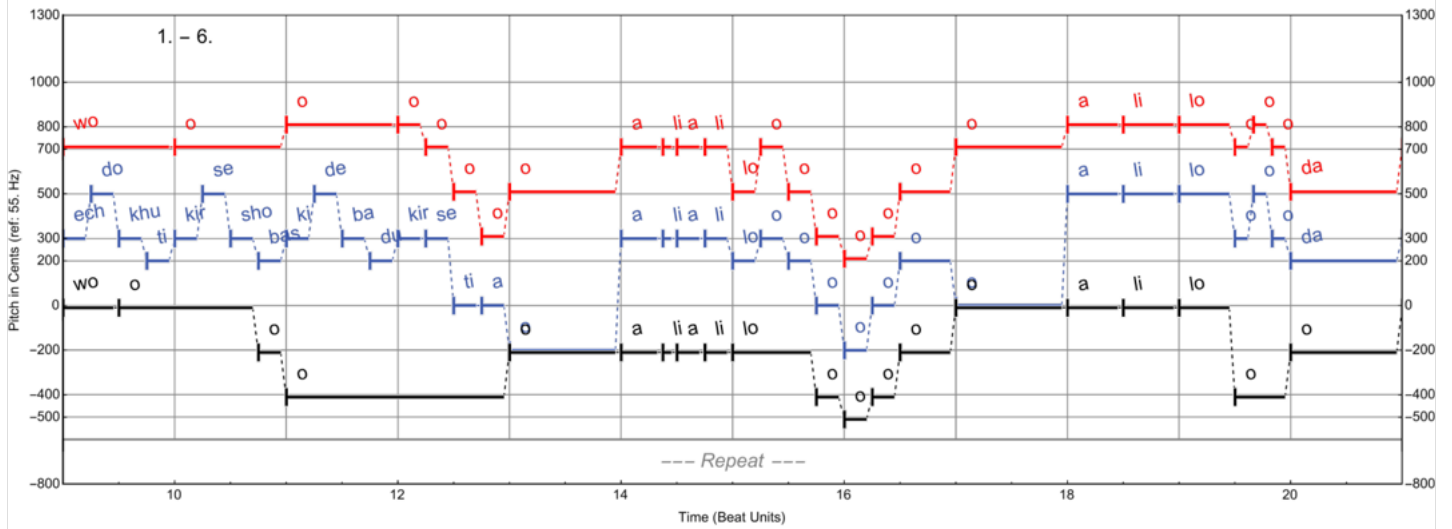

a li lo da wo i a li lo o da wo a li lo o o o da

1. ech do khu ti kir se sho bas ki de ba du kir se ti a o a li a li o o o o o o a li lo o o o da

2. a khal tsa na mi ga khwa man gho ront go gi ta nu as wa ....

3. ak men dze li a she ne ba stu ma re bis gakh shi re ba ....

4. men dze li shi a shi ne ba an tsi ko re khan si tso ba ....

5. a ghu sia a ka ghu si a ghezh mi ko bu ka ghu si a ....

6. kri stes sho bas mo gi lo tsav a sho bis ma khare be li vart....

7. kris tes sho o o bas kris te sho bas mo gi lot sav a ka mshvi do ba



### Aragvis Piruli (12TET)

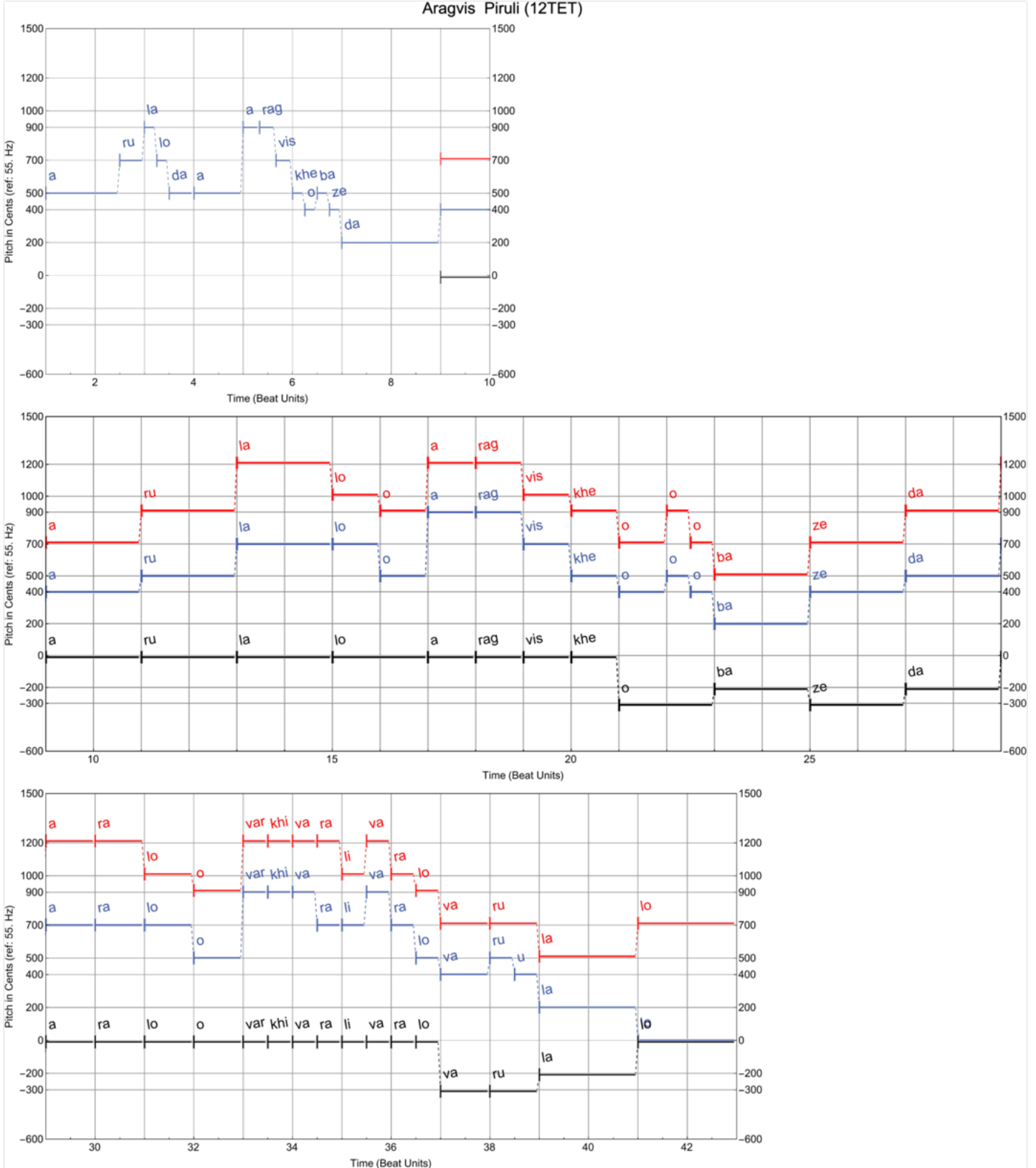

1. a ru la lo da a rag vis khe o ba ze da a ru la lo o a rag vis khe o o o ba ze da a ra lo o var khi va ra li va ra lo va ru u la lo
2. a ru la lo da tska ro cha mo dis an ka ra a ru la lo o tska ro cha mo di i is an ka ra var khi va ra li va ra lo va ru u la lo
3. a ru la lo da tska ro ze ka li cha mo va a ru la lo o tska ro ze ka li i i cha mo va var khi va ra li va ra lo va ru u la lo
4. a ru la lo da la ma zi ki ser qar qa ra a ru la lo o la ma zi ki se e er qar qa ra var khi va ra li va ra lo va ru u la lo



This work is licensed under a Creative Commons Attribution International 4.0 License. © 2024 Copyright held by Frank Scherbaum.



### Batonebis Nanina (12TET)

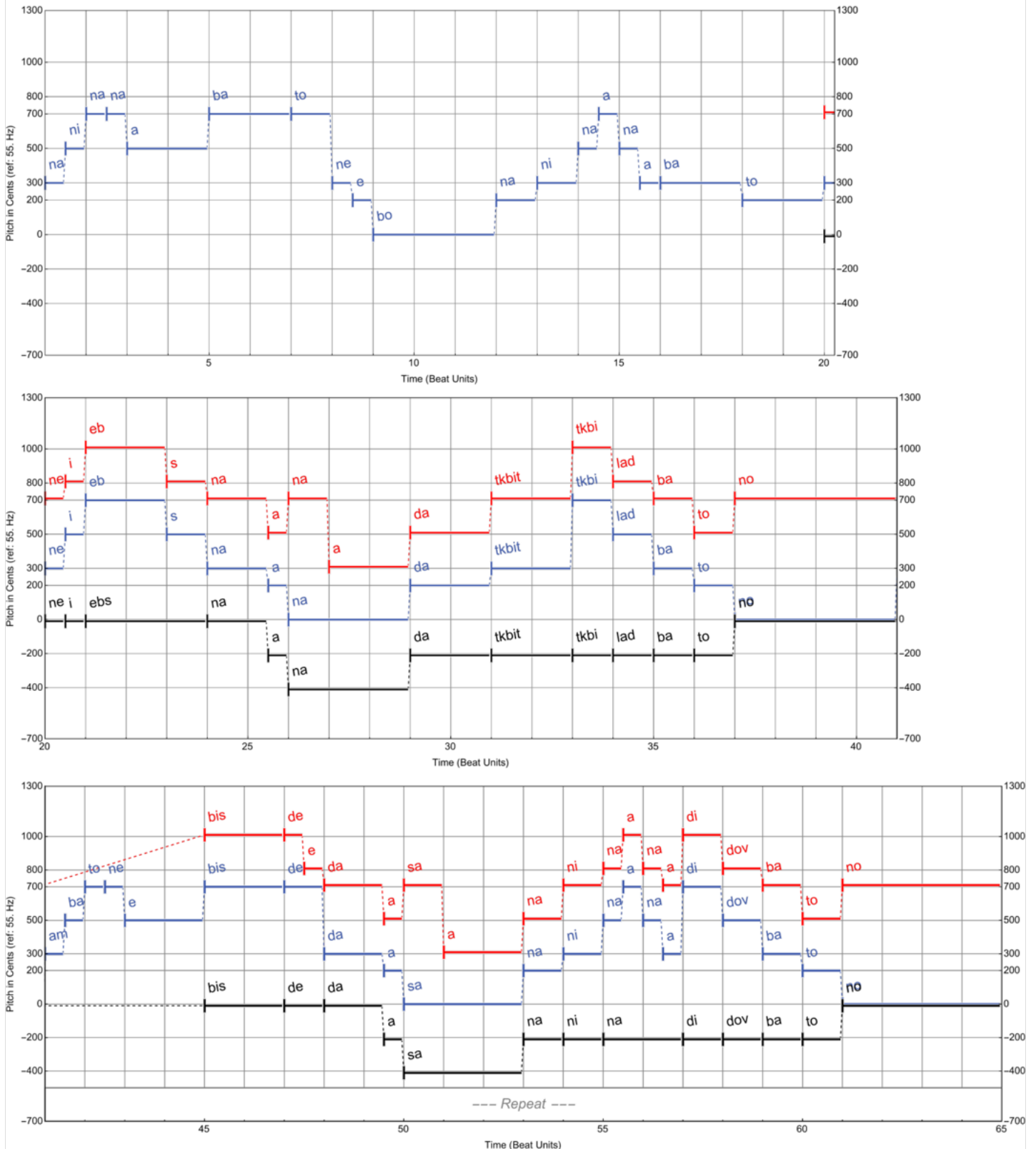

1. na ni na na a ba to o ne e bo na ni na a na a ba to ne i eb s na a na da tkbit tkbi la d ba to no

2. am ba to ne e bis de e da a sa na ni na a na a di do v ba to no
3. ud gi a o kros a a kva a ni na ni na a na a di do v ba to no
4. shig ut sevt ba a to ni i shvi i li na ni na a na a di do v ba to no
5. khan di khan ga a da a art se e ven na ni na a na a di do v ba to no
6. khan di khan na a nas se et qvi i an na ni na a na a di do v ba to no
7. na ni na na a ba to o ne e bo na ni na a na a tkbi la d ba to no



This work is licensed under a Creative Commons Attribution International 4.0 License. © 2024 Copyright held by Frank Scherbaum.

### Batonebis Simghera (12TET)

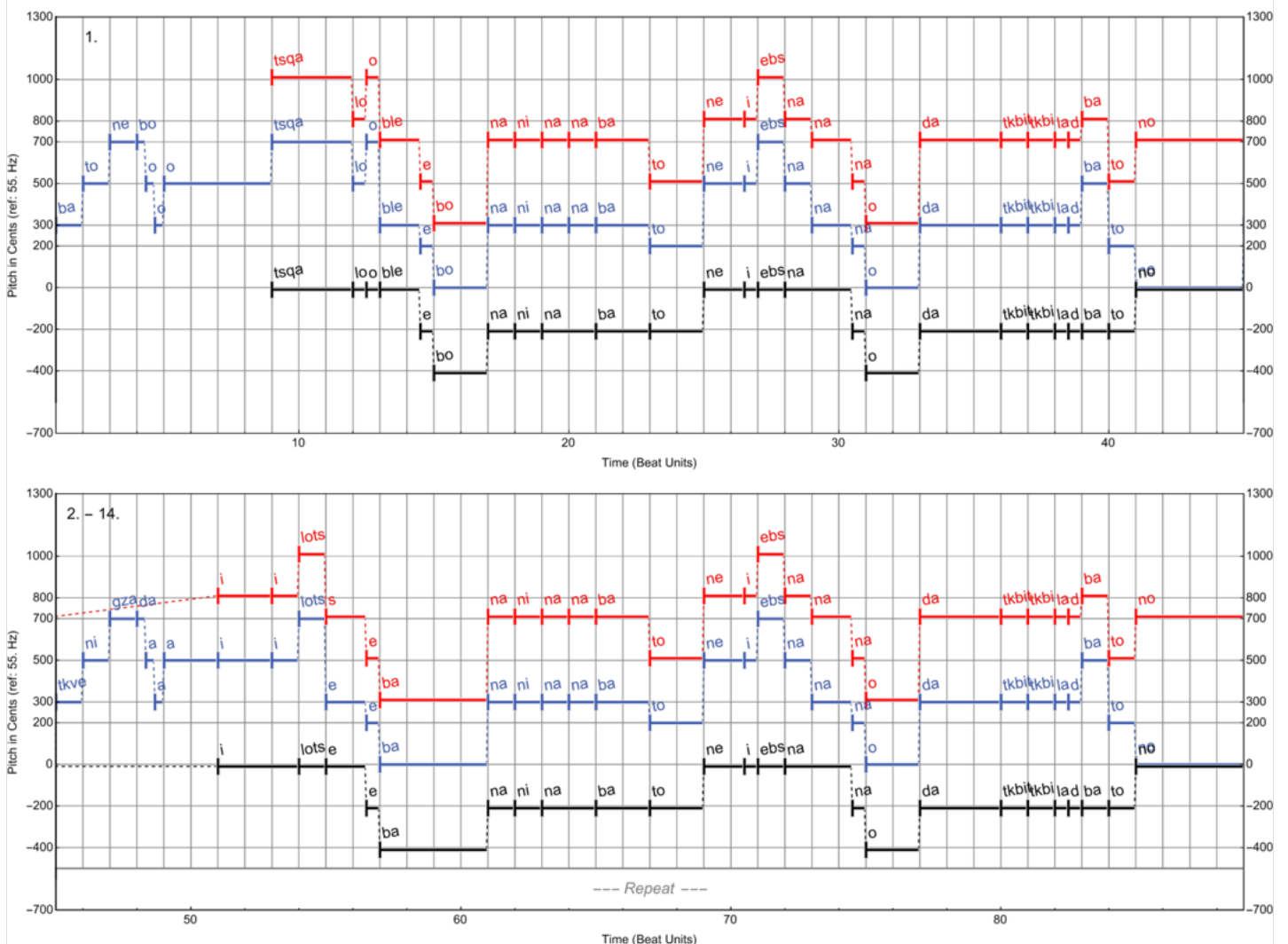

1. ba to ne bo o o tsqa lo o ble e bo na ni na na ba to ne i ebs na na na o da tkbit tkbi la d ba to no
2. tkve ni gza da a a a i i lots e e ba na ni na na ba to ne i ebs na na na o da tkbit tkbi la d ba to no
3. tkve nsa gza sa a a a vu pe en va ar dsa ....
4. shvi di da dzma a a a i ga av di i vart ....
5. shvid so pels mo o o o ve pi i ne e bit ....
6. i se dav di i i i vart so o pe el shi ....
7. chi ti sa ar a a a gvi pre e ni i a ....
8. bav shi vi tsa a ar da gvi tsve e ni i a ...
9. am ba to ne e e e bis de e da a sa ...
10. ud gi a o o o o kros a ak va a ni ...
11. shig u tsevs ba a a a to ni i sh vi i li ...
12. khan da khan ga a a a da art se e ven ...
13. ia vkri pe e e e var di i sha a le ...
14. tsin ba to ne e e ebs ga vu sha a le ...



This work is licensed under a Creative Commons Attribution International 4.0 License. © 2024 Copyright held by Frank Scherbaum.

### Batonebo (12TET)

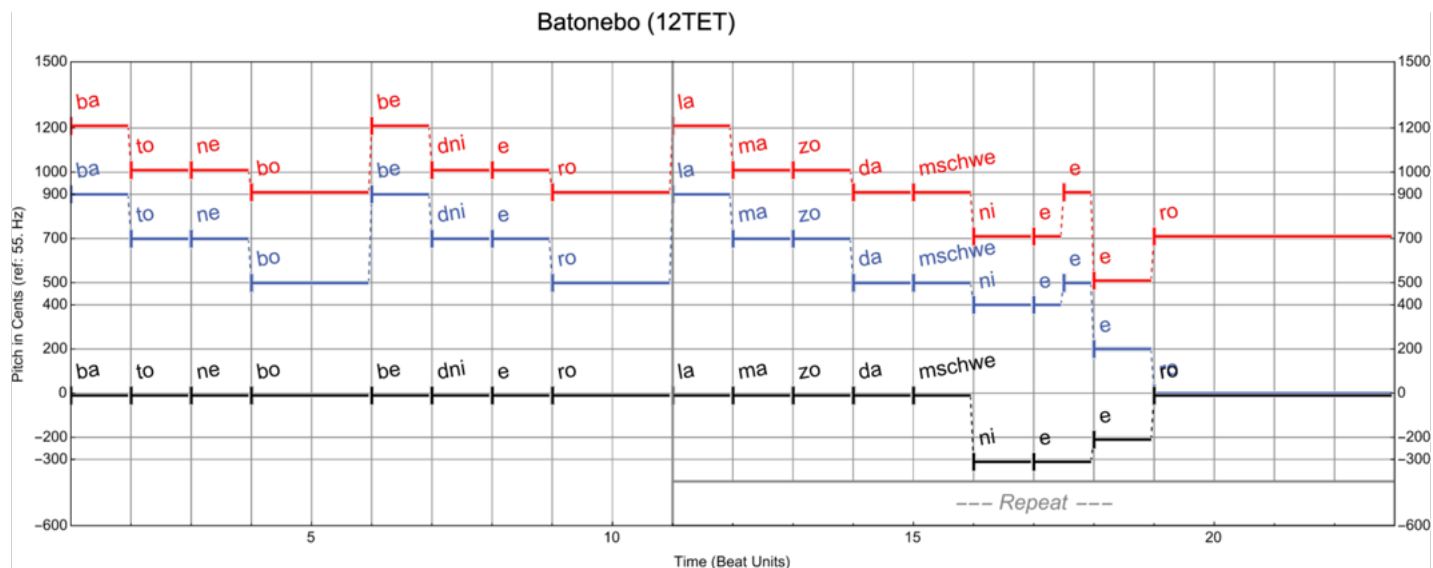

1. ba to ne bo be dni e ro ||: la ma zo da mschwe ni e e ro :||
2. sche nsa mo su lsa a gza sa ||: i a da wa rdi pe ni i i a :||
3. ro gorts tkbi lad mo o brdza ndi ||: i sa tkbi lad tsa a brdza a a ndi :||
4. ba to ne bo be dni e ro la ma zo da mschwe ni e e ro



This work is licensed under a Creative Commons Attribution International 4.0 License. © 2024 Copyright held by Frank Scherbaum.

### Batonebo (12TET)

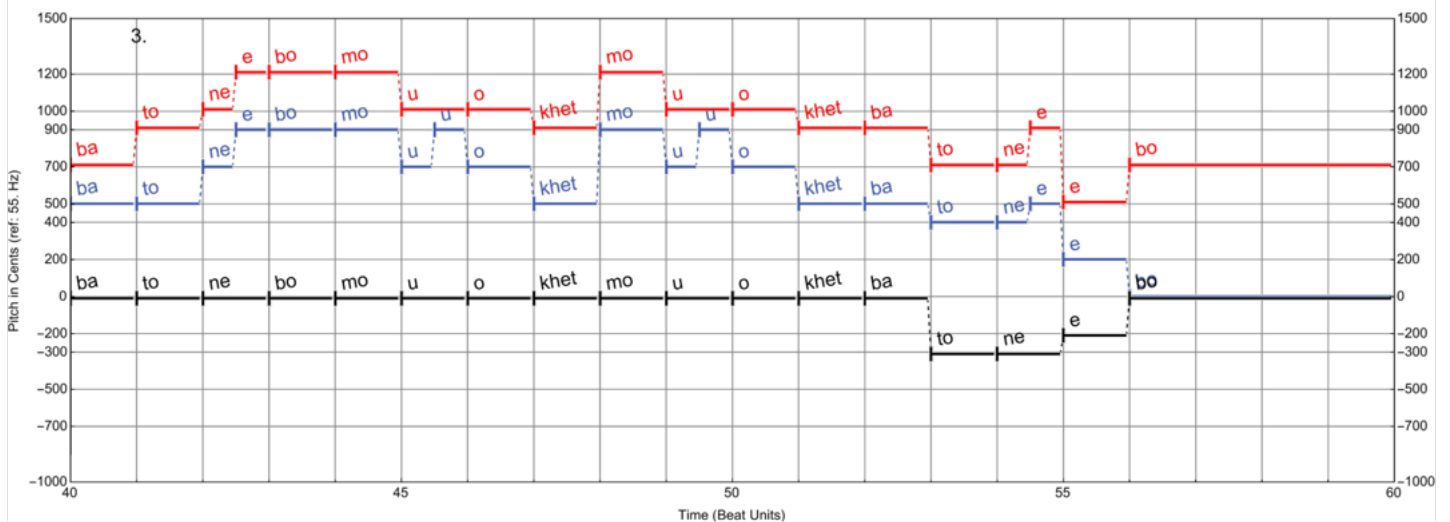
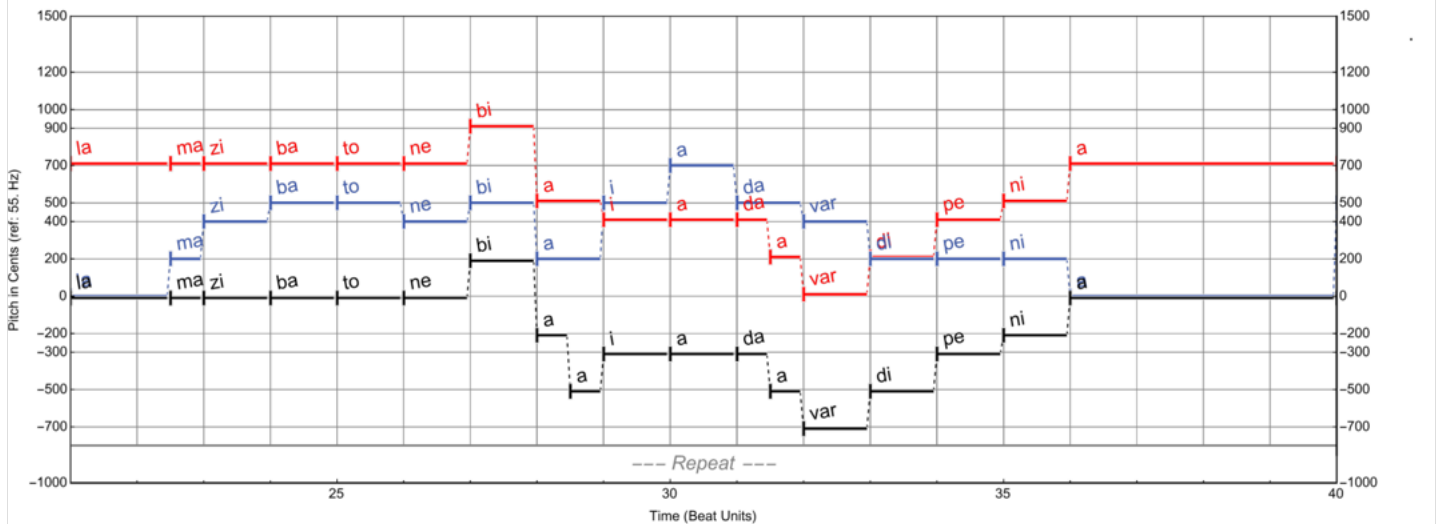
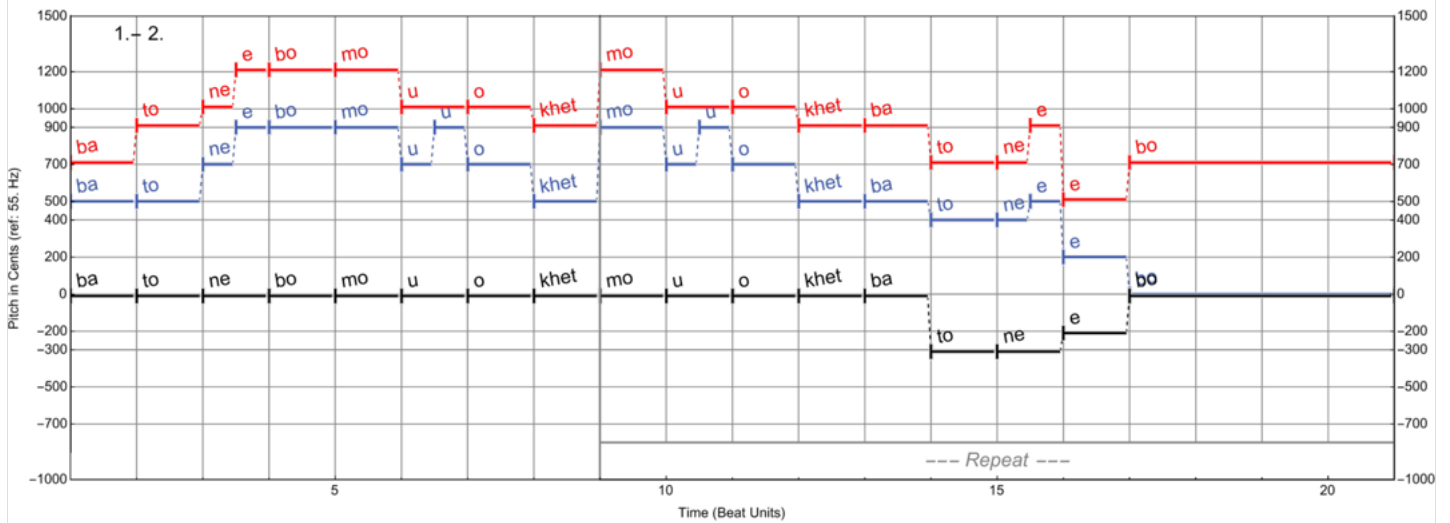

1. ba to ne e bo mo u u o khet ||: mo u u o khet ba to ne e e bo :|| la ma zi ba to ne bi a i a da var di pe ni a :||
2. tet ri ckhva a ri da thki is jo gi ||: mor bi is ci kan ma ikh tu u u na :||: ga u khar dat ba to ne bsa da uc bat pi ri ib ru na :||
3. ba to ne e bo mo u u o khet mo u u o khet ba to ne e e bo



This work is licensed under a Creative Commons Attribution International 4.0 License. © 2024 Copyright held by Frank Scherbaum.

### Deda Mogikvdesa (12TET)

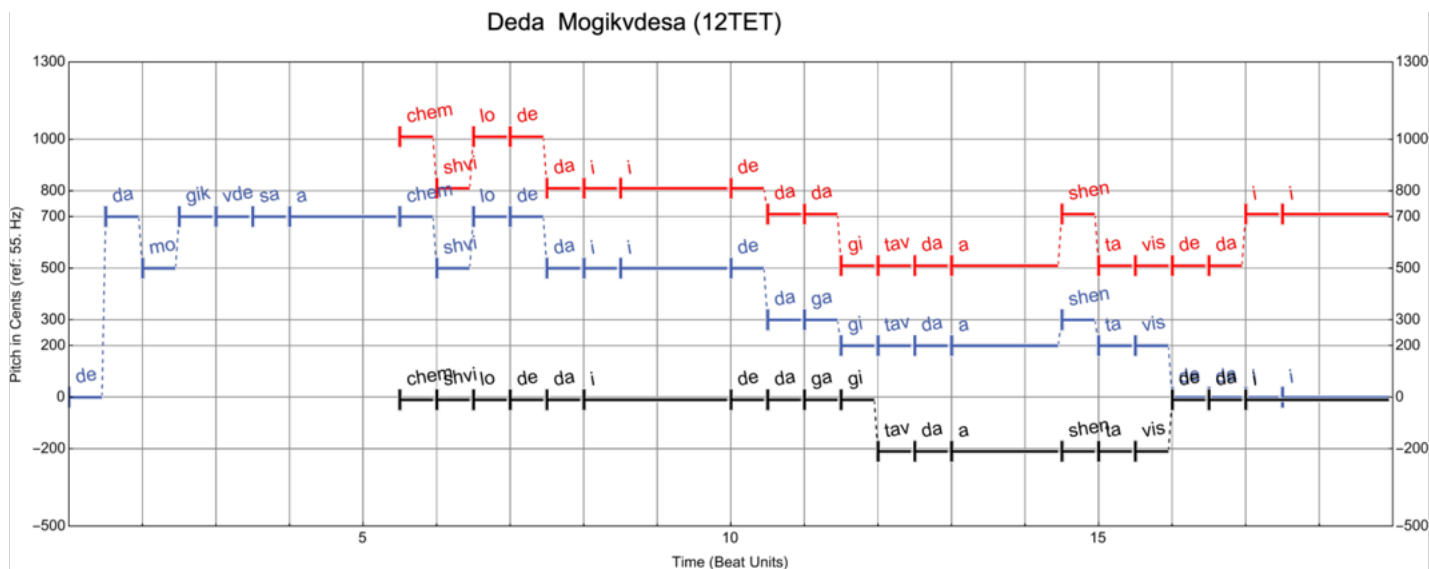

1. de da mo gik vde sa a chem shvi lo de da i i de da ga gi tav da a shen ta vis de da i i
2. shvi lo sit gas tsi re e gu da it na ba di i an jokh sit gas tsi re e bekt mi qur de bu li i
3. shvi lo me shen tsken sa a shav u na gir se da a a ghvi rebs she va qri i tqe ve lad gush ve ba a



This work is licensed under a Creative Commons Attribution International 4.0 License. © 2024 Copyright held by Frank Scherbaum.

### Deli Deli (12TET)

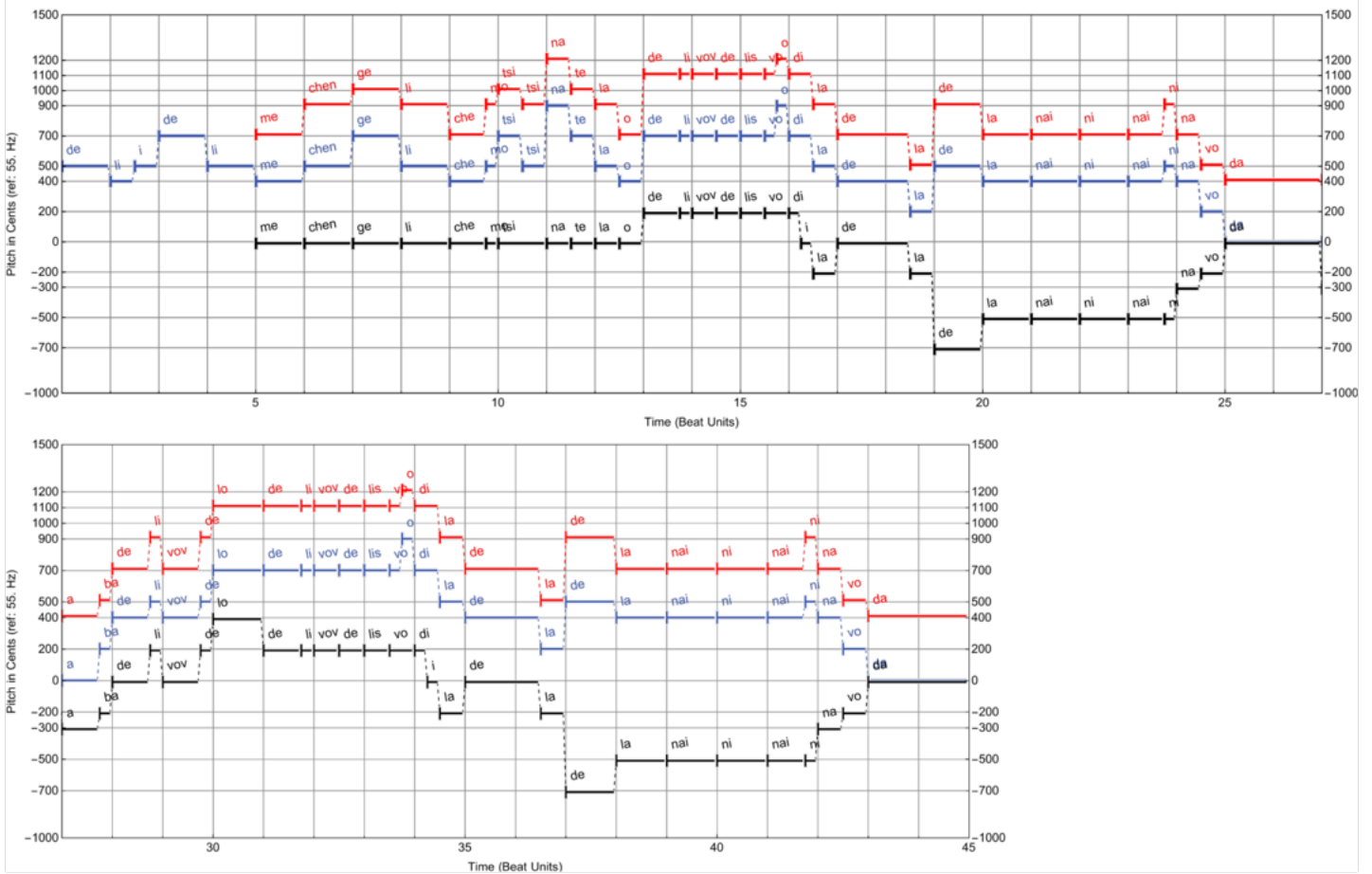

1. de li i de li me chen ge li che mo tsi tsi na te la o de li vov de lis vo o di la de la de la nai ni nai ni na vo da  
a ba de li vov de lo de li vov de lis vo o di la de la de la nai ni nai ni na vo da
2. a ke e da ni da she nam de a ke da ni da she nam de li vov de lis vo o di la de la de la nai ni nai ni na vo da  
a ba de li vov de lo de li vov de lis vo o di la de la de la nai ni nai ni na vo da
3. var di i mas khi a qe lam de var di mas khi a qe lam de de li vov de lis vo o di la de la de la nai ni nai ni na vo da  
a ba de li vov de lo de li vov de lis vo o di la de la de la nai ni nai ni na vo da

BY-NC-SA This work is licensed under a Creative Commons Attribution International 4.0 License. © 2024 Copyright held by Frank Scherbaum.

### Dghres Saghtoman Madlman (12TET)

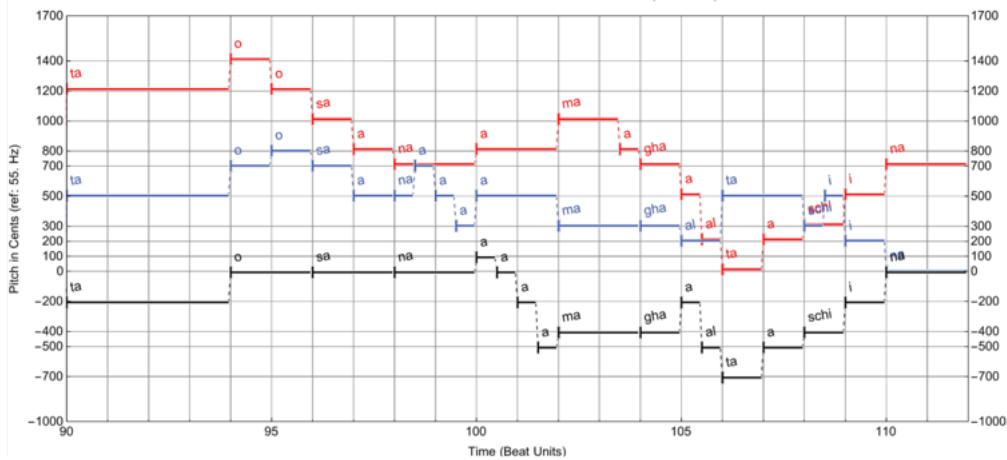
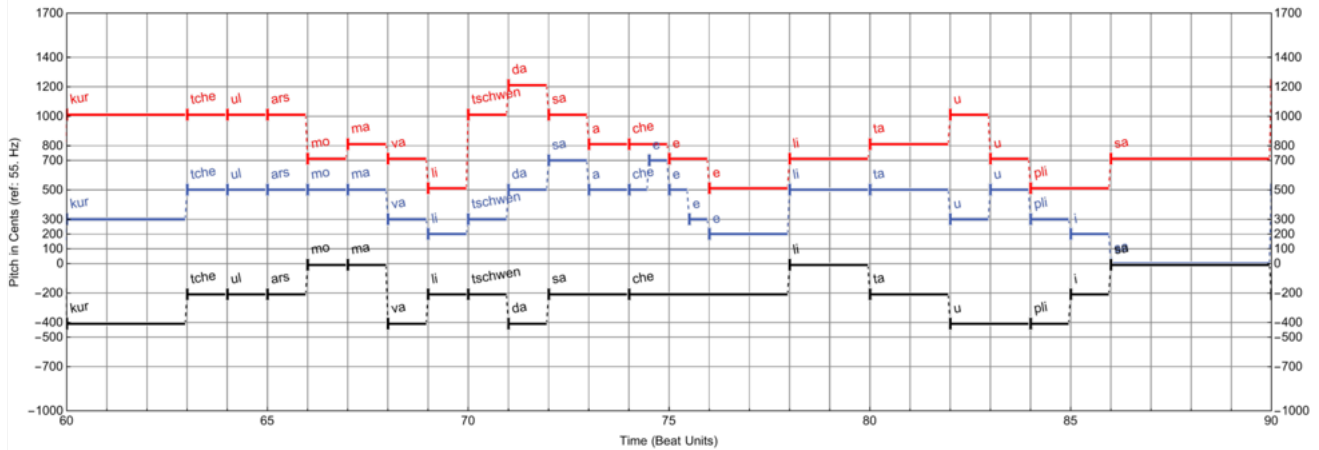
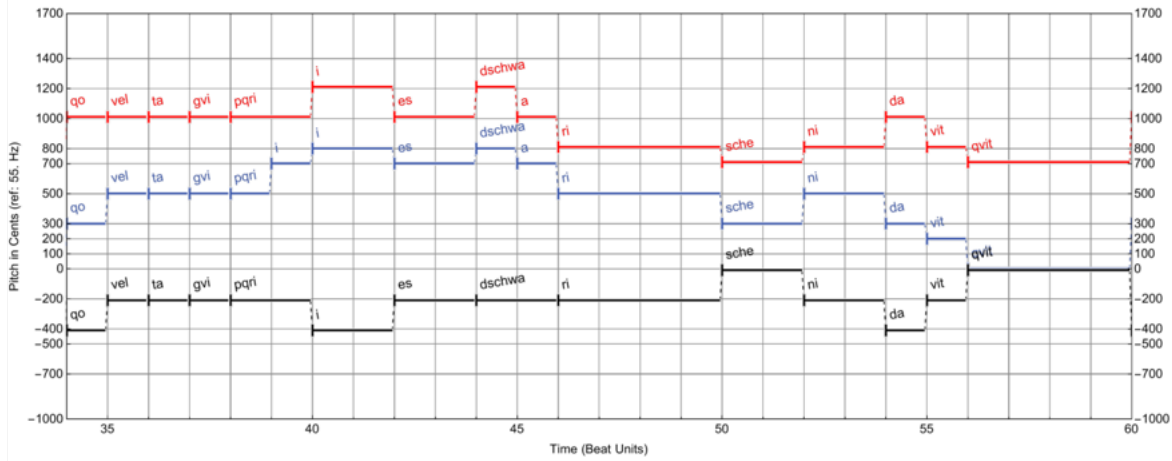
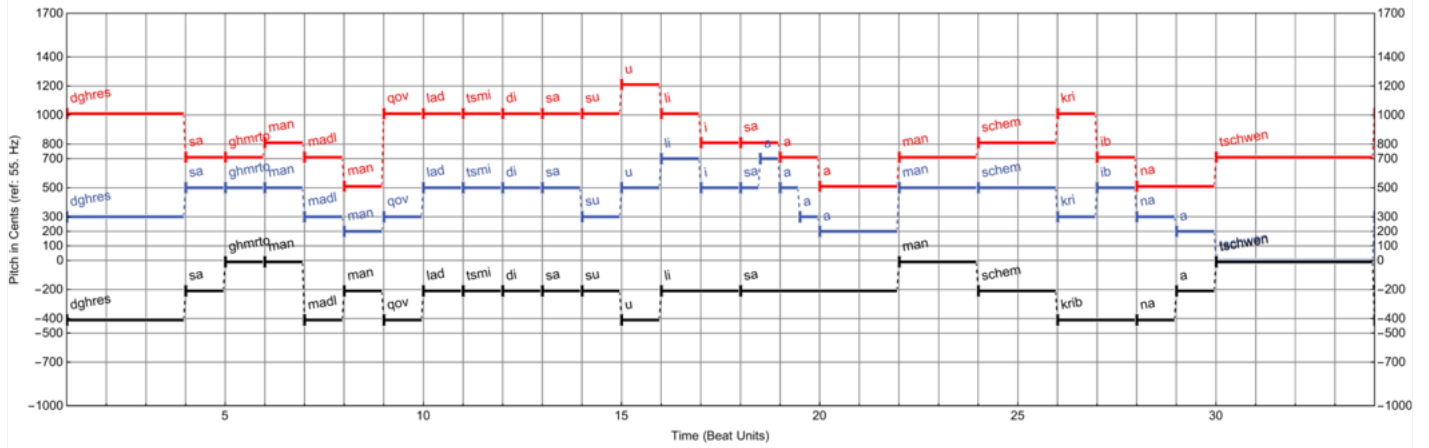

dghres sa ghmrto man madl man qov lad tsmi di sa su u li i sa a a a man schem kri ib na a tschwen  
 qo vel ta gvi pqri i i es dschwa a ri sche ni da vit qvit  
 kur tche ul ars mo ma va li tschwen da sa a che e e e li  
 ta u u pli i sa ta o sa a na a a a ma gha al ta schi i i na



This work is licensed under a Creative Commons Attribution International 4.0 License. © 2024 Copyright held by Frank Scherbaum.



### Dida Voi Nana (12TET)

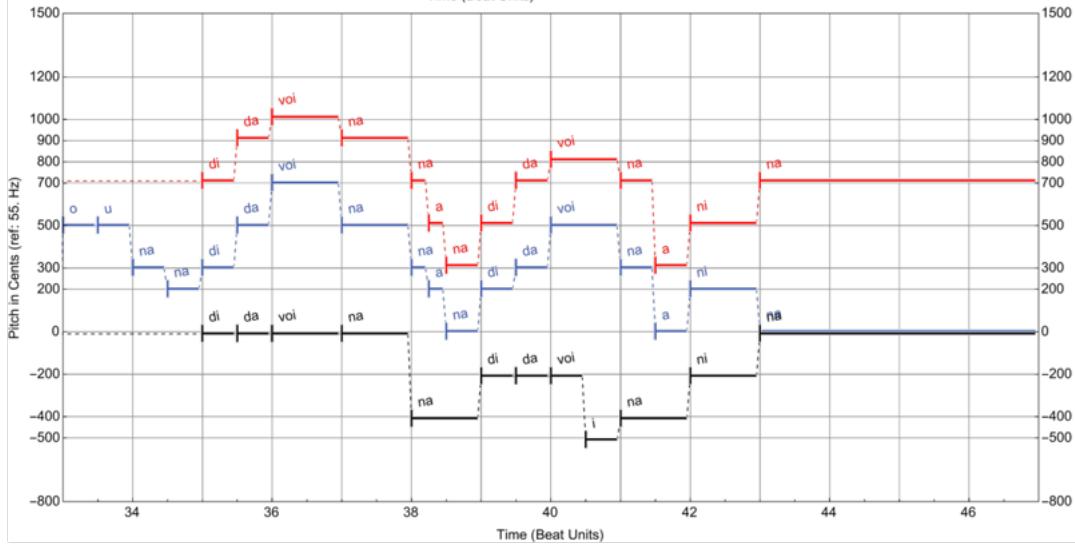
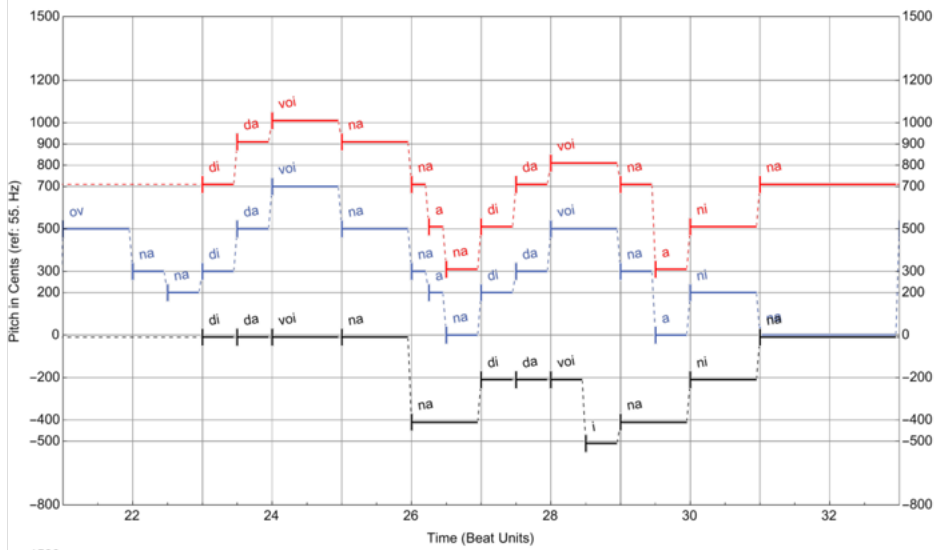
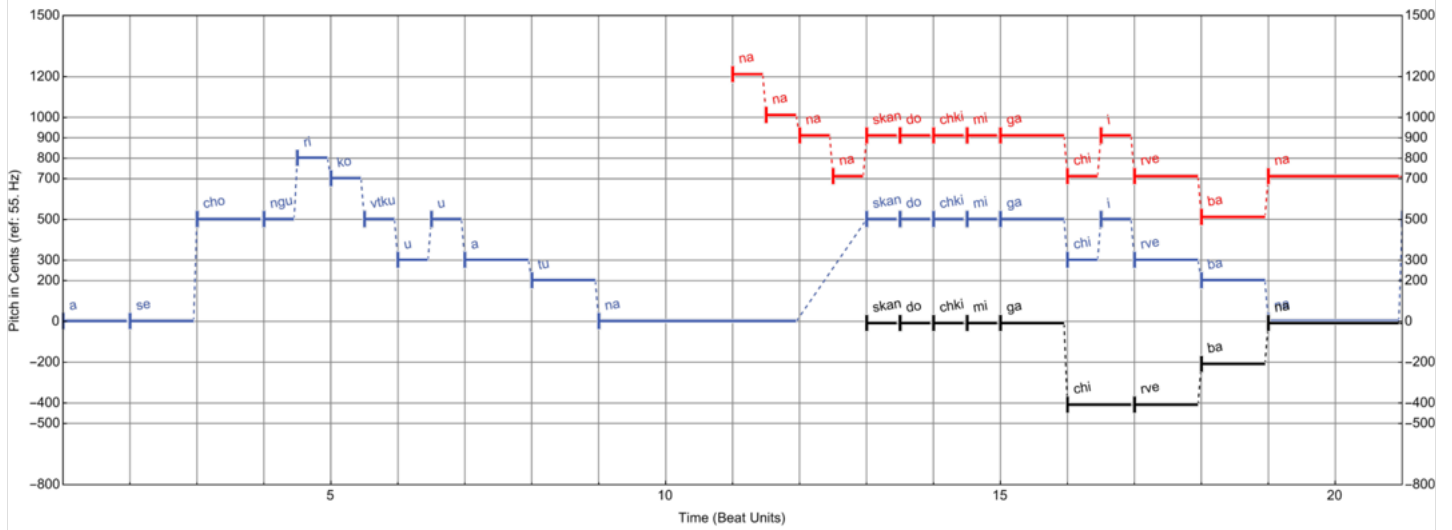

a se cho ngu ri ko vtku u u a tu na skan do chkimi gachi i rve ba na ov na na di da  
 voi na na a na di da voi na a ni na o u na na di da voi na na a na di da voi na a ni na



This work is licensed under a Creative Commons Attribution International 4.0 License. © 2024 Copyright held by Frank Scherbaum.

### Dideba (12TET)

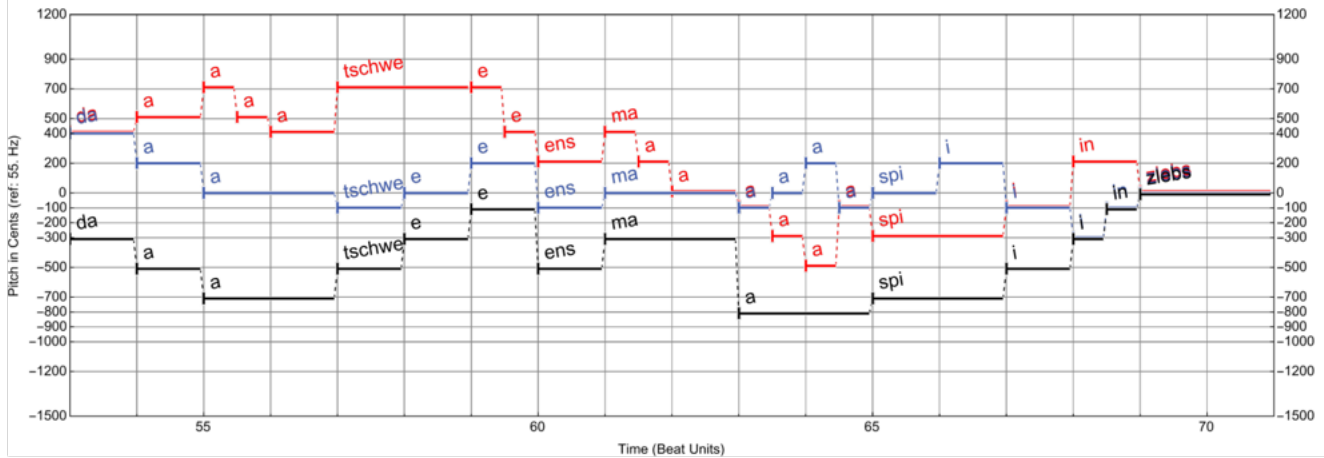
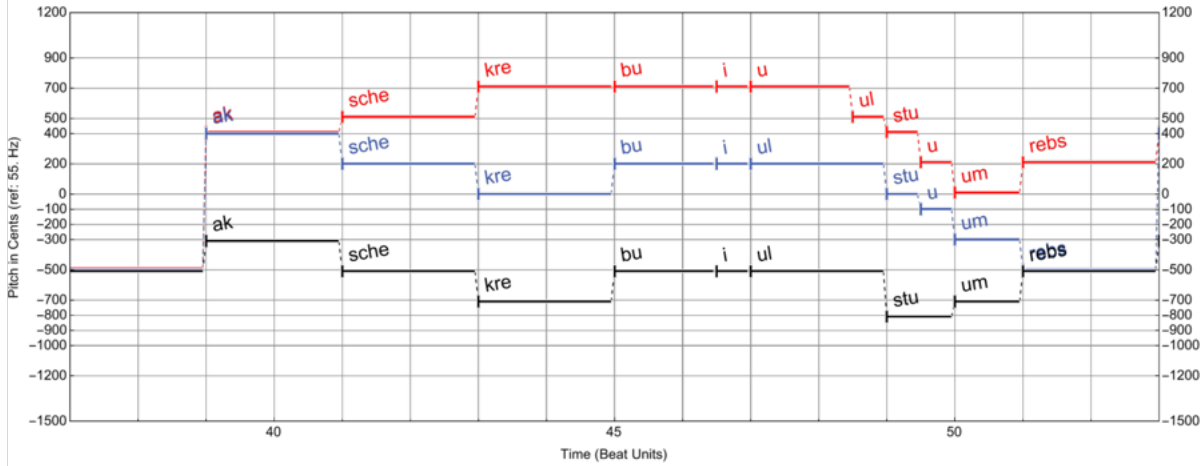
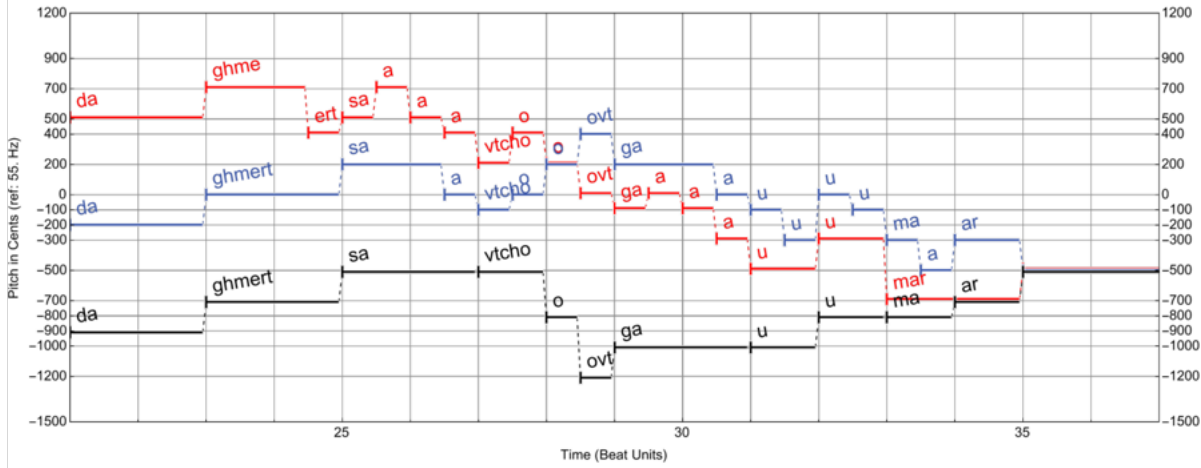
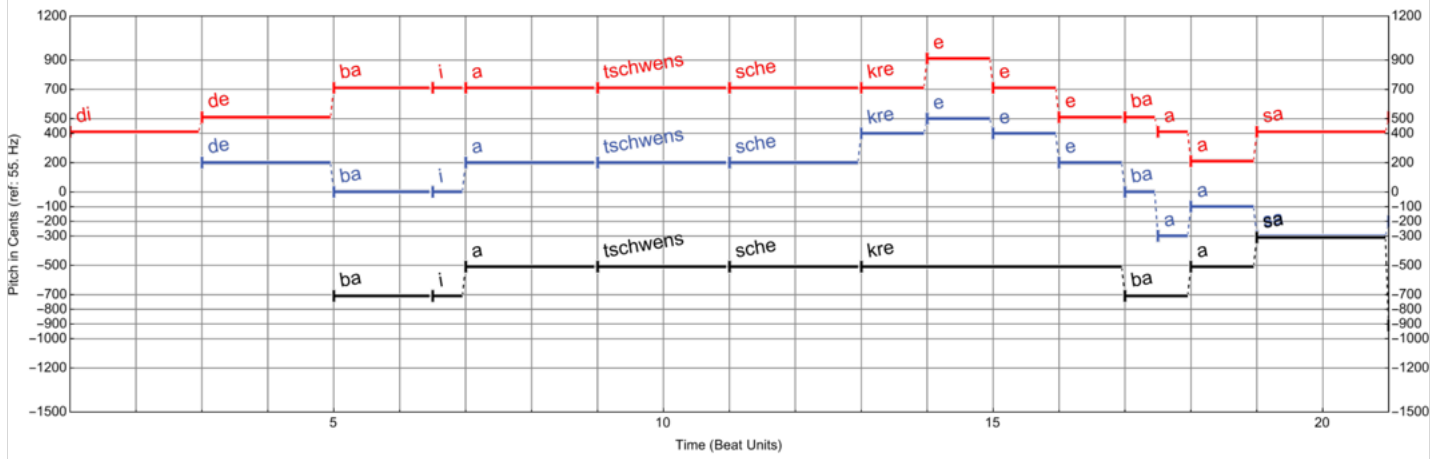

di de ba i a tschwens sche kre e e e ba a a sa da ghmert sa a vtcho o o ovt ga a u u u ma a ar tschos  
ak sche kre bu i ul stu u um rebs da a a tschwe e e ens ma a a a a spi i i in zlebs



This work is licensed under a Creative Commons Attribution International 4.0 License. © 2024 Copyright held by Frank Scherbaum.

### Erekles Mravalzhamier (12TET)

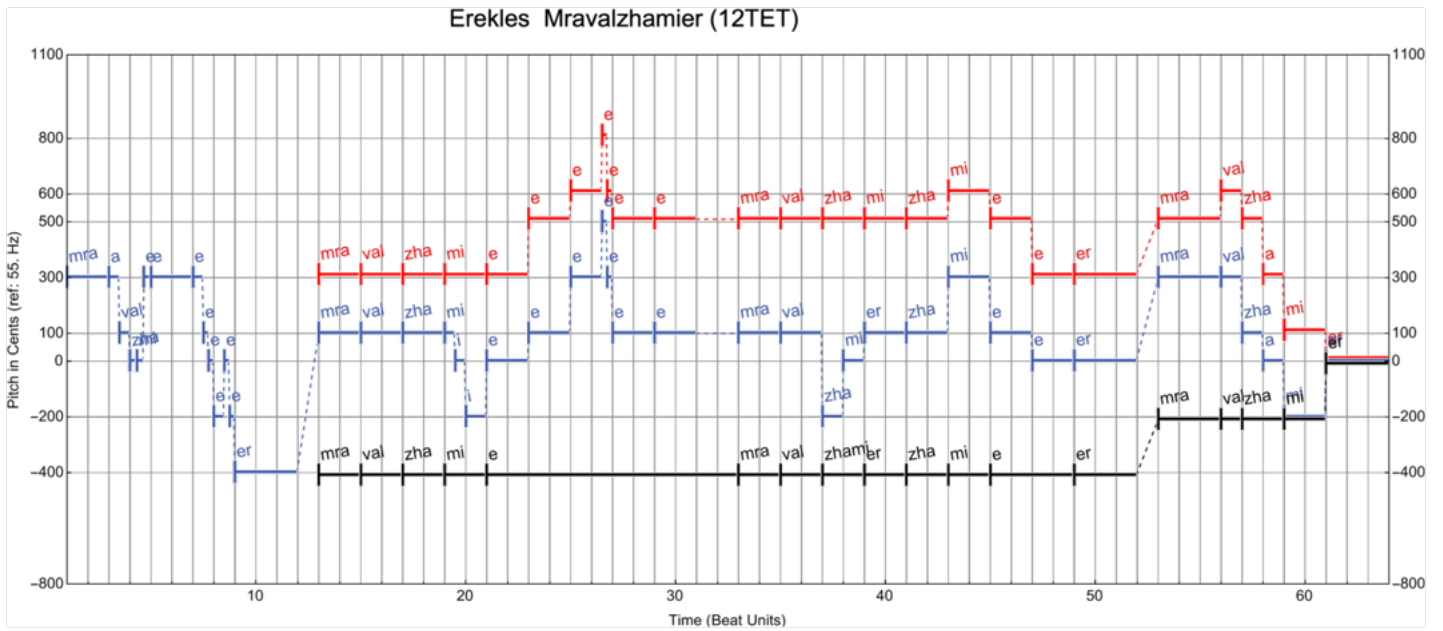

mra a val zha mi e e e e e e e er mra val zha mi i i e e e e e e mra val zha mi er zha mi e e er mra val zha a mi er



This work is licensed under a Creative Commons Attribution International 4.0 License. © 2024 Copyright held by Frank Scherbaum.

### Es Akvani Kharatuli (12TET)

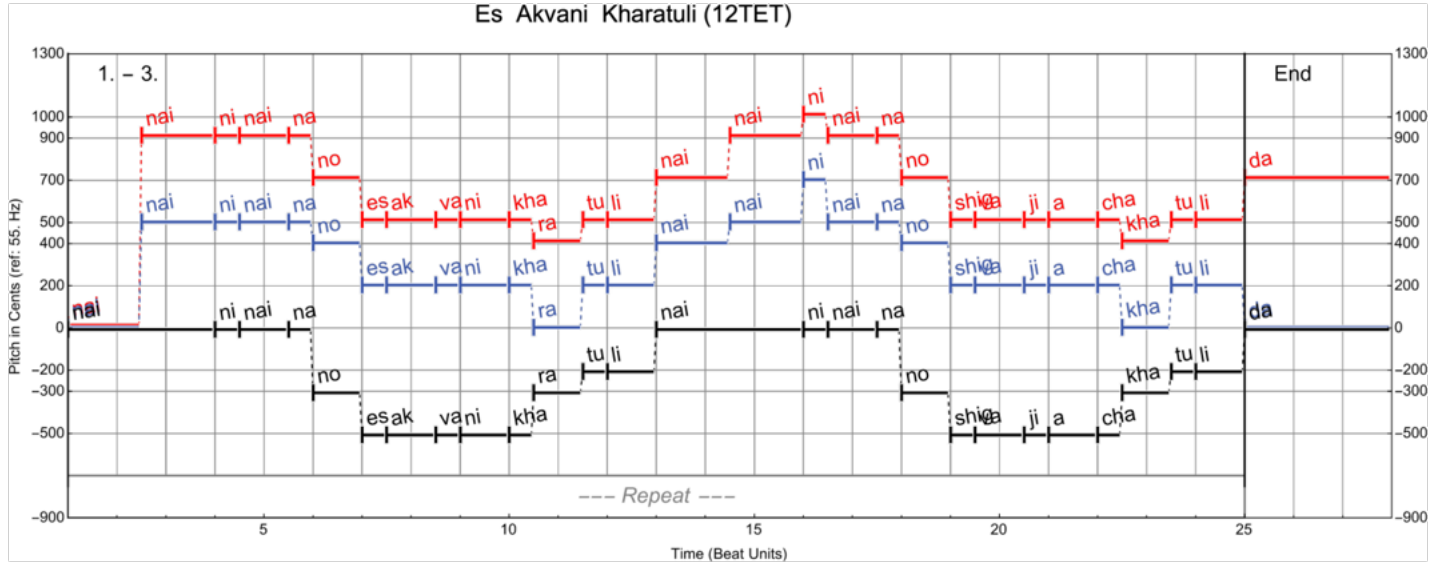

nai nai ni nai na no es ak va ni kha ra tu li nai nai ni nai na no shig va ji a cha kha tu li  
 nai nai ni nai na no es ak va ni tsab li sa o nai nai ni nai na no shi ga mtso li dar bi sa o  
 nai nai ni nai na no na ni da na ni da na no nai nai ni nai na no na ni da na ni da na no  
 da



This work is licensed under a Creative Commons Attribution International 4.0 License. © 2024 Copyright held by Frank Scherbaum.

### Ghighini (12TET)

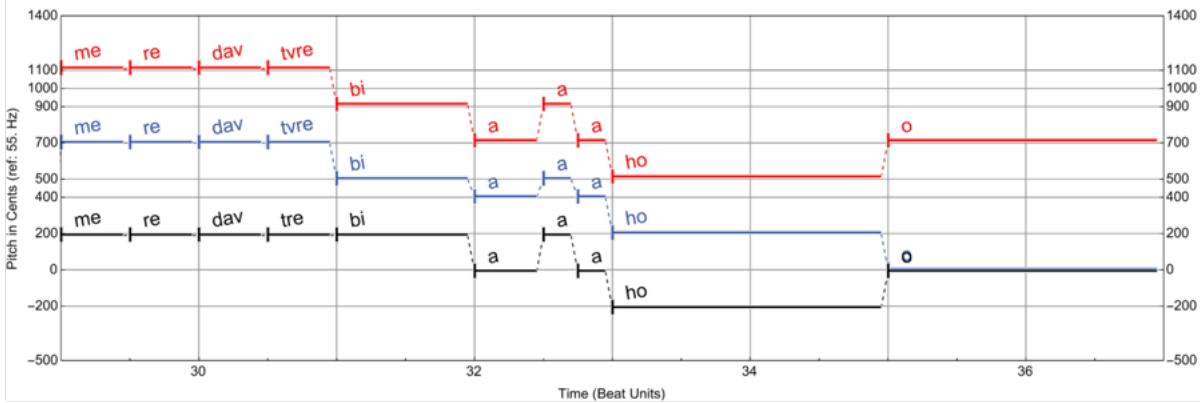
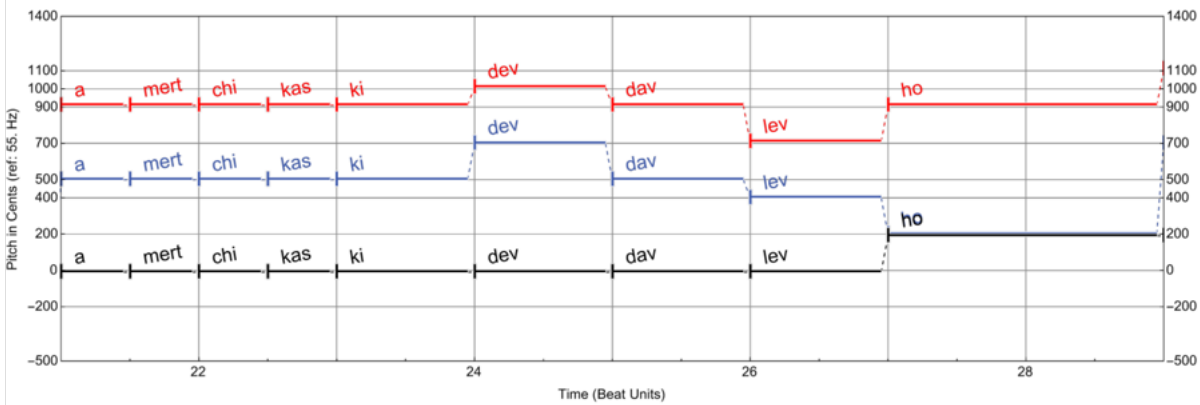
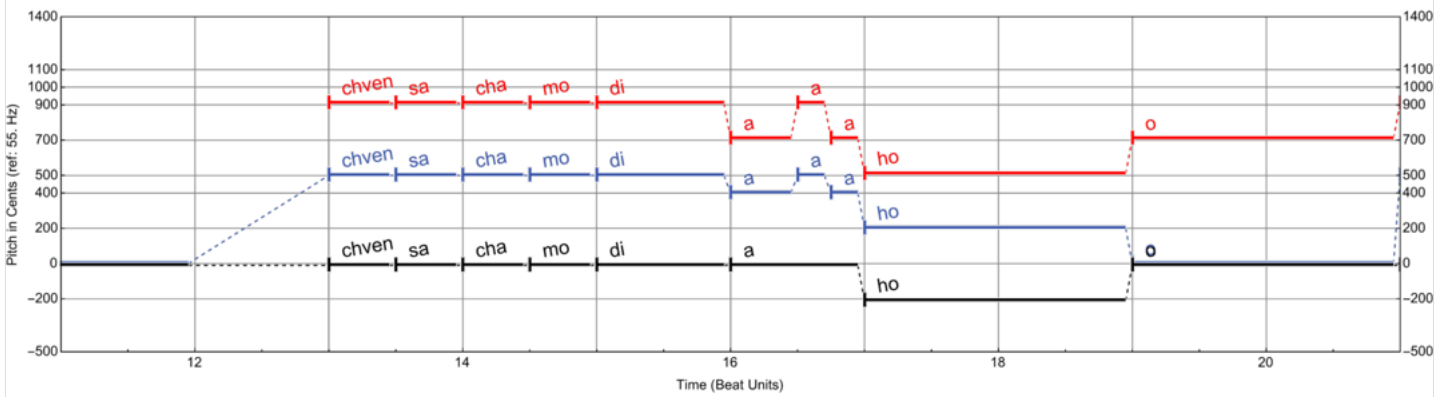
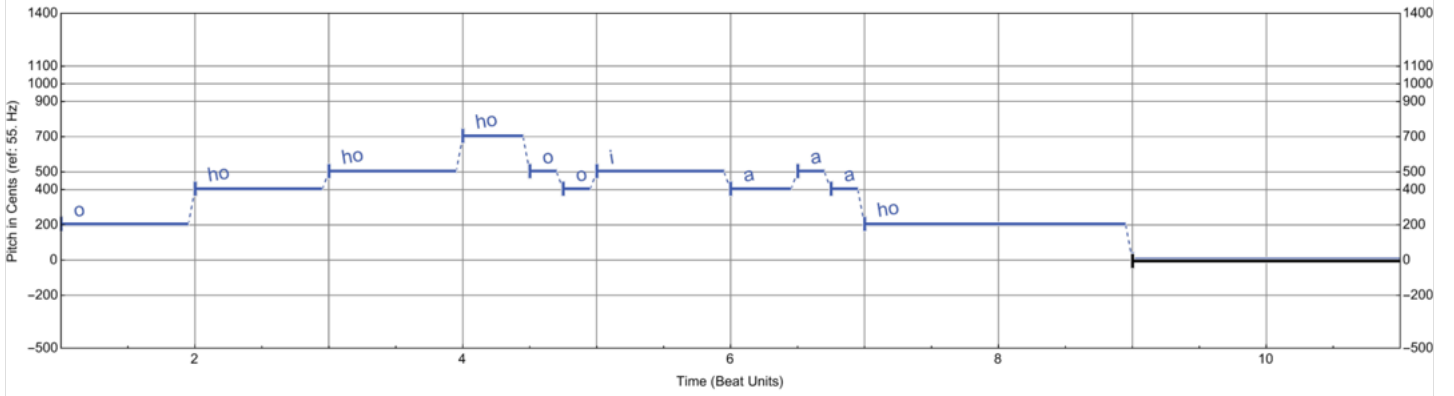

o ho ho ho o o i a a a ho o chven sa cha mo di a a a ho o a mert chi kas ki dev dav lev ho me re dav tvre bi a a a ho o  
 var be ri ka tsi a a a ho o a kha lu khi she mo mats dev ho cho khots ar ma tsvi a a a ho o  
 var be ri ka tsi a a a ho o shro mats mi khvars gar jats mi khvars ho ar va zar ma tsvi a a a ho o



This work is licensed under a Creative Commons Attribution International 4.0 License. © 2024 Copyright held by Frank Scherbaum.

### Ghmerti Upali (12TET)

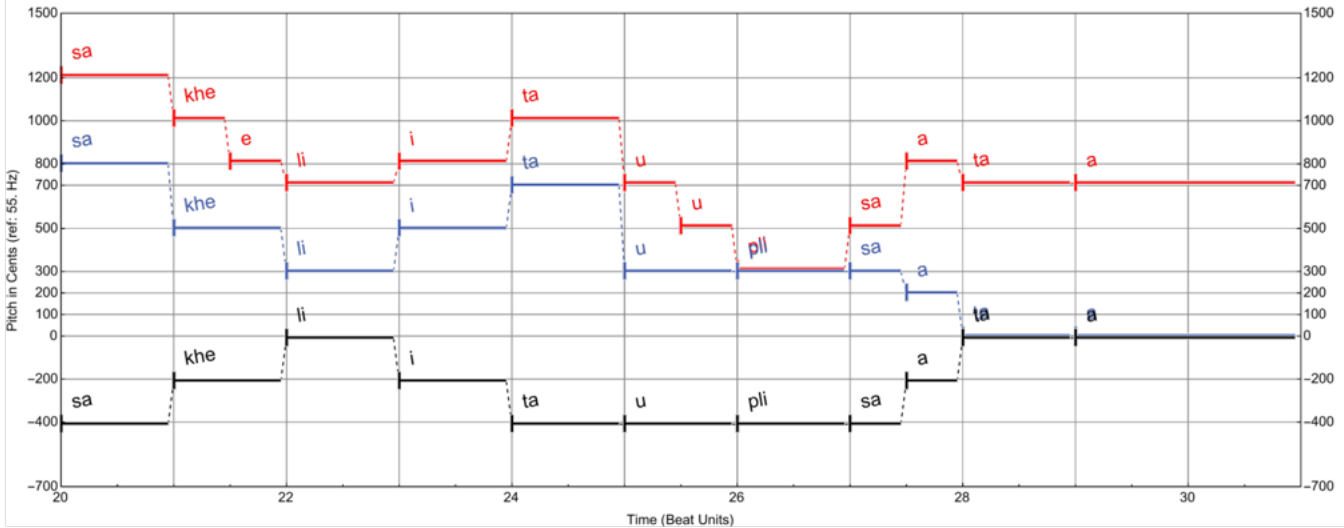
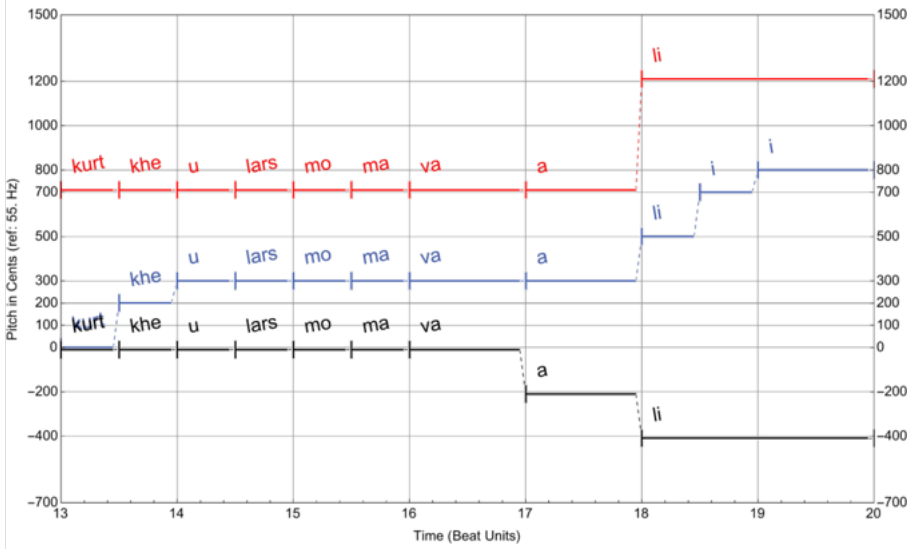
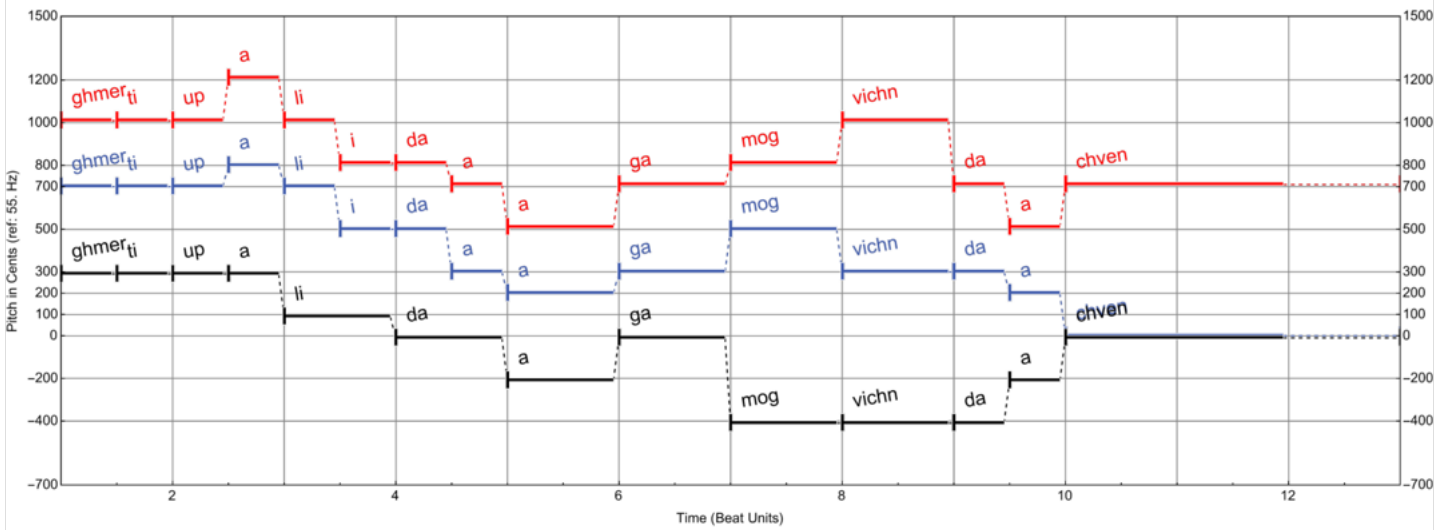

ghmer ti up a li i da a a ga mog vichn da a chven kurt khe u lars mo ma va a li i i sa khe li i ta u pli sa a ta a



This work is licensed under a Creative Commons Attribution International 4.0 License. © 2024 Copyright held by Frank Scherbaum.

# Heyamoli (12TET)

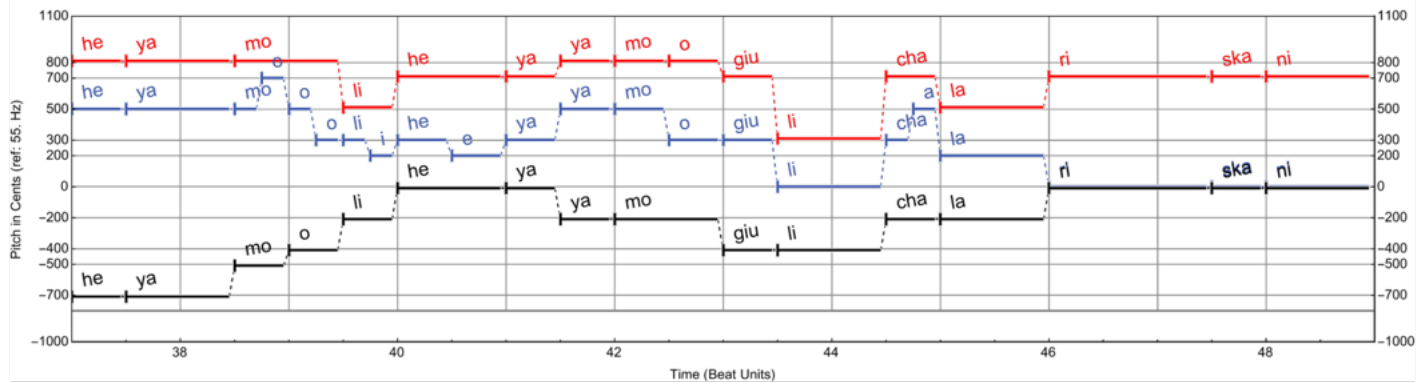
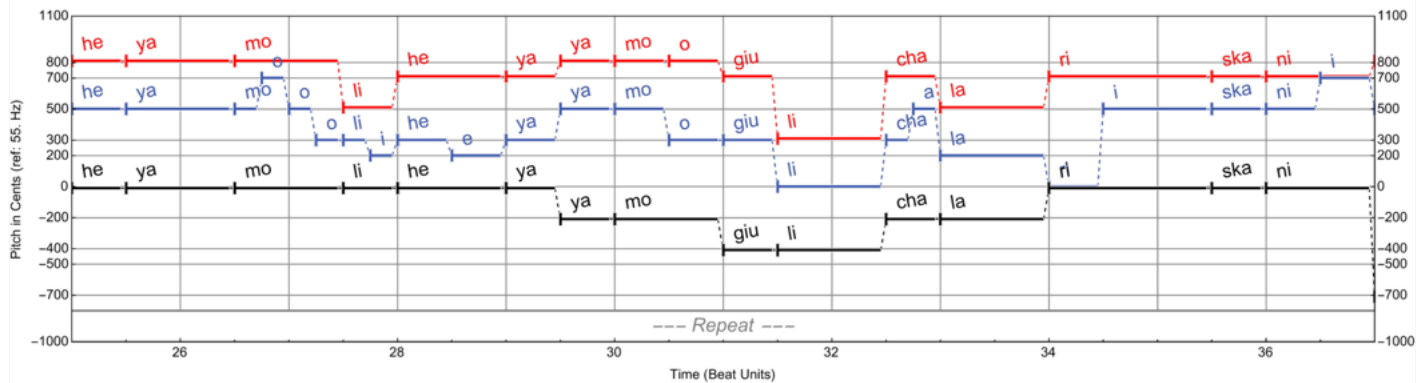
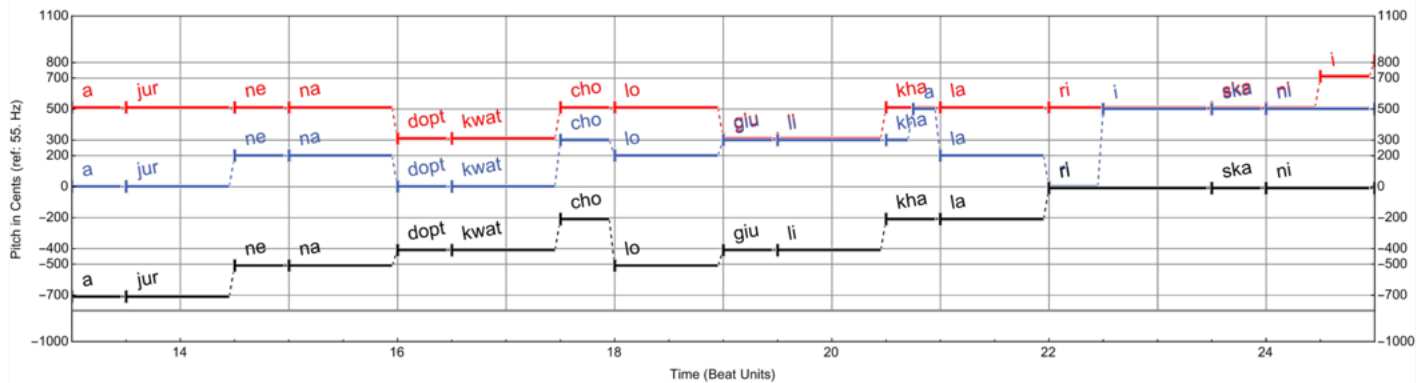
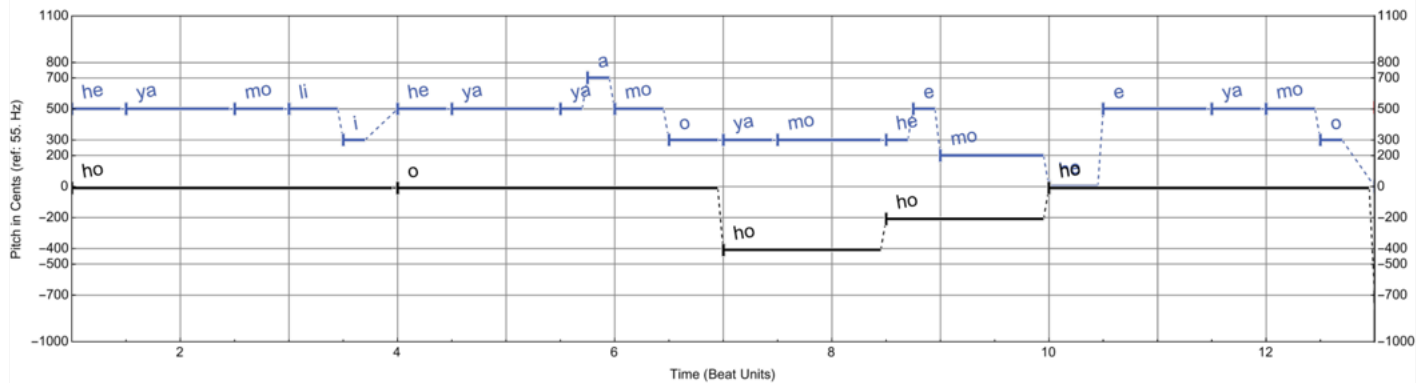

he ya mo li i he ya ya a mo o ya mo he e mo he e ya mo o

1. a jur ne na dopt kwat cho lo giu li kha a la ri i ska ni he ya mo o o li i he e ya ya mo o giu li cha a la ri ska ni  
he ya mo o o li i he e ya ya mo o giu li cha a la ri ska ni
2. me ptko tscha re na na ba ba ska ni wi i rwa re e ska ni he ya mo o o li i he e ya ya mo o ska ni wi i rwa re e ska ni  
he ya mo o o li i he e ya ya mo o ska ni wi ir wa re ska ni
3. i ri schi gu ri di ru ar war i wu u gu ri i ska ni he ya mo o o li i he e ya ya mo o wa ri wu u gu ri i ska ni  
he ya mo o o li i he e ya ya mo o wa ri wu u gu ri ska ni



This work is licensed under a Creative Commons Attribution International 4.0 License. © 2024 Copyright held by Frank Scherbaum.



Ia Patonepi (12TET)

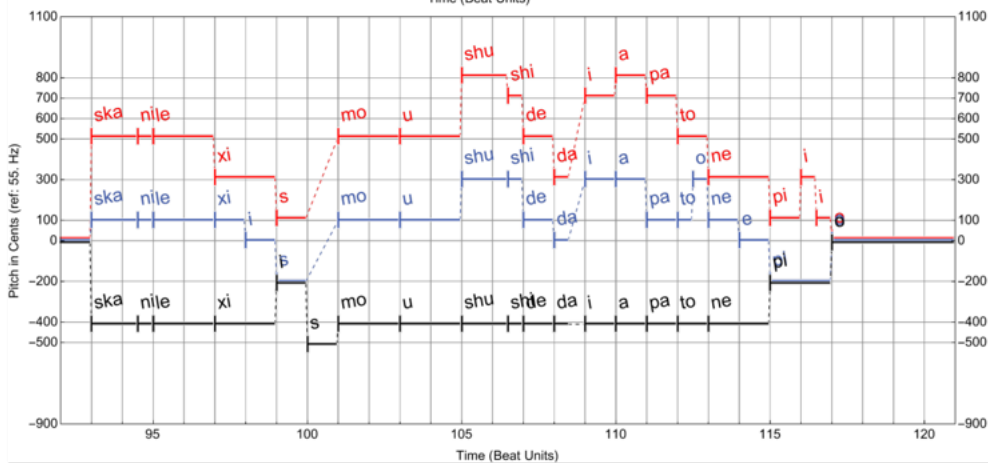
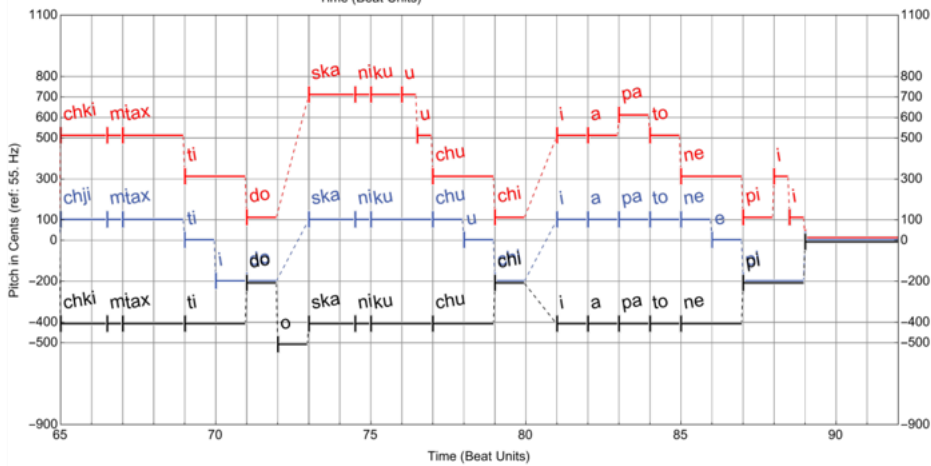
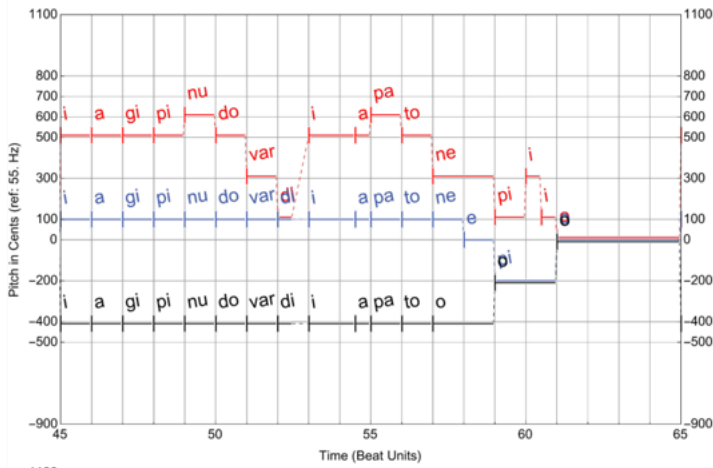
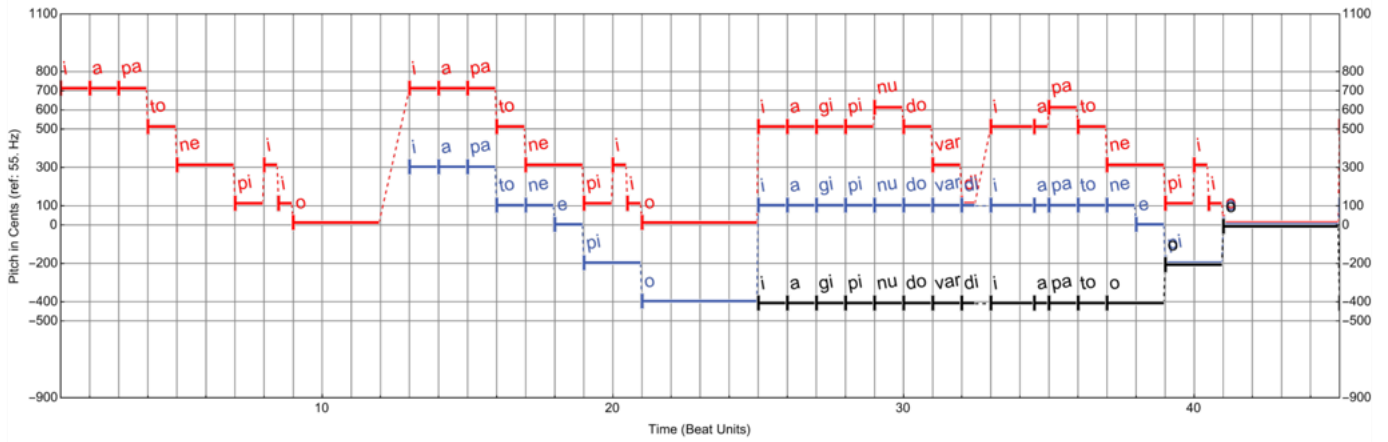

i a pa to ne pi i o i a pa to ne pi i o i a gi pi nu do var di i a pa to ne pi i o i a gi pi nu do var di i a pa to ne pi i o  
 chki mi tax ti do ska ni ku u u chu chi i a pa to ne pi i o ska ni le xi s mo u shu shi de da i a pa to ne pi i o

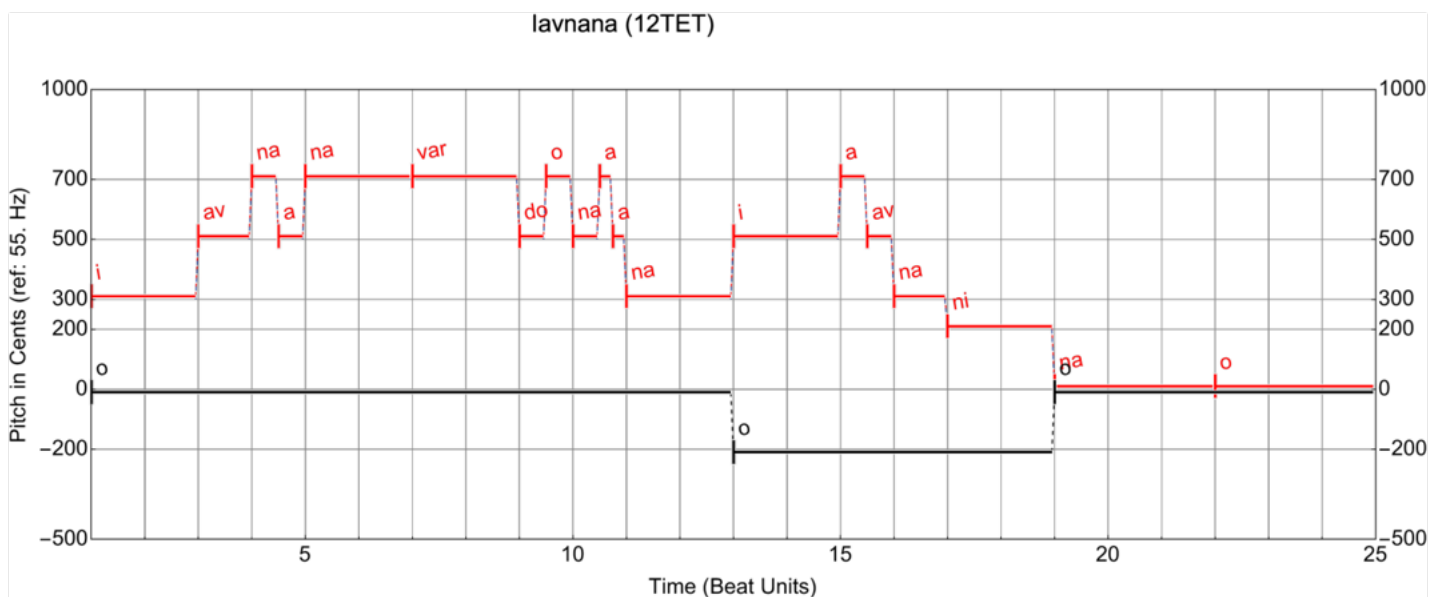

1. i av na a na var do o na a a na i a av na ni na o  
 2. e gre tkbi i lad u dar de la a a ad ram da a ga dzi na o  
 3. i a gu un dis ma ra an shi i i a i a av na ni na o  
 4. shig ghvi i i no da la li bchvi so o o i a av na ni na o

5. shig al vi is khe a mo su la a a a i a av na ni na o  
 6. nor chi i i a da rto sa shli so o o i a av na ni na o  
 7. zed bul bu u li she mom dja ra a a a i a av na ni na o  
 8. ga sa pr e nad prta sa shli so o o o i a av na ni na o



This work is licensed under a Creative Commons Attribution International 4.0 License. © 2024 Copyright held by Frank Scherbaum.

### Ima Mtazeda (12TET)

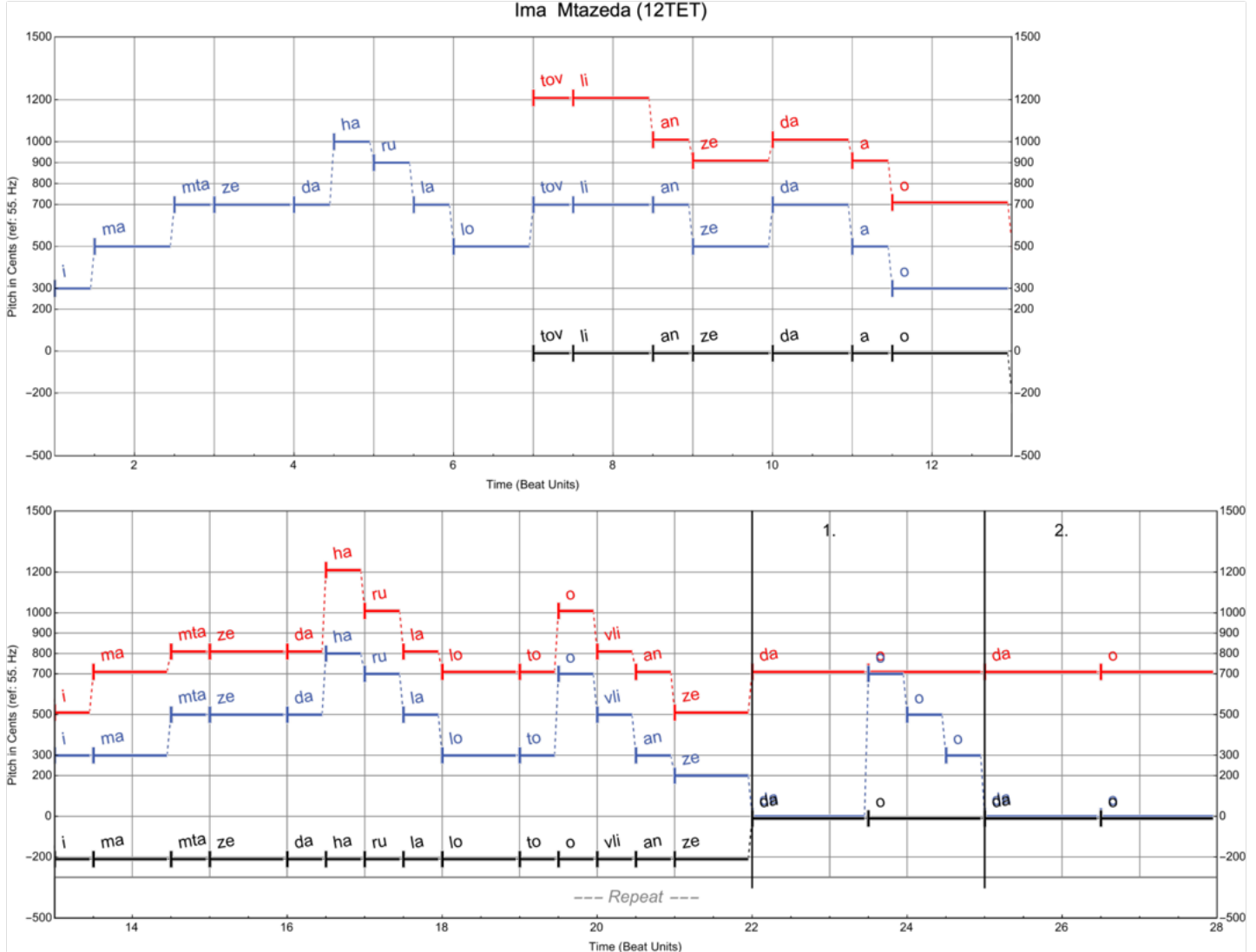

1. i ma mta ze da ha ru la lo tov li an ze da a o i ma mta ze da ha ru la lo to o vli an ze da o o da o
2. i a dav te se ha ru la lo var di mo su la a o
3. i a ko cham dis ha ru la lo var di mu khlam di i o
4. ir mi sa jo gi ha ru la lo mta she ve o da a o
5. ne tav ed zo vat ha ru la lo ar ga e te la a to
6. i ma mta ze da ha ru la lo tov li an ze da a o i ma mta ze da ha ru la lo to o vli an ze da o o da o



This work is licensed under a Creative Commons Attribution International 4.0 License. © 2024 Copyright held by Frank Scherbaum.

### Jvaris Tsinasa (12TET)

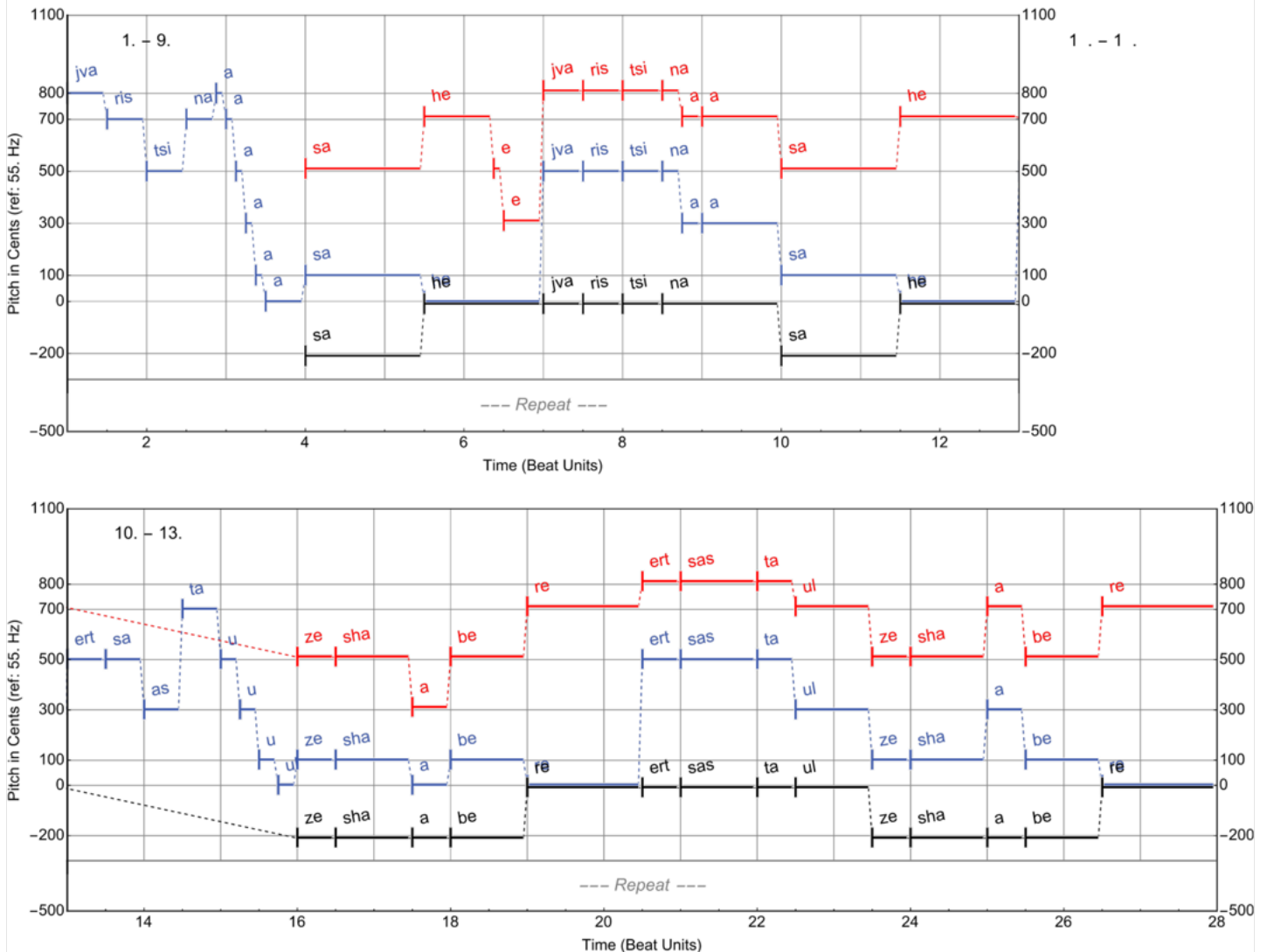

1. jva ris tsi na a a a a sa he jva ris tsi na a a sa he
2. she mov dgi pe e e e e e khi he she mov dgi pe e e khi he
3. gtsqa lob det ghme e e e e e ti he gtsqa lob det ghme e e ti he
4. an ge lo ze e e e e e bi he an ge lo ze e e bi he
5. rad gam qa re e e e e e sa he rad gam qa re e e sa he
6. shen kris tev ghme e e e e e to he shen kris tev ghme e e to he
7. das tse re jva a a a a ri he das tse re jva a a ri he
8. a mat qo i i i i i i l ta he a mat qo i i i l ta he
9. er tad shaq ri i i i i i l ta he er tad shaq ri i i l ta he
10. ert sa as ta u u u ul ze sha a be re ert sas ta ul ze sha a be re
11. da do o de du u u u pal ga gvi kha re da do de do pal ga gvi kha re
12. e ji i bo ne e e e pes ga u mar jos e ji bo ne pes ga u mar jos
13. ert sa sta u u u u ul ze sha a be re ert sa sta ul ze sha a be re



This work is licensed under a Creative Commons Attribution International 4.0 License. © 2024 Copyright held by Frank Scherbaum.

Jvarsa Shensa (12TET) 1 of 2

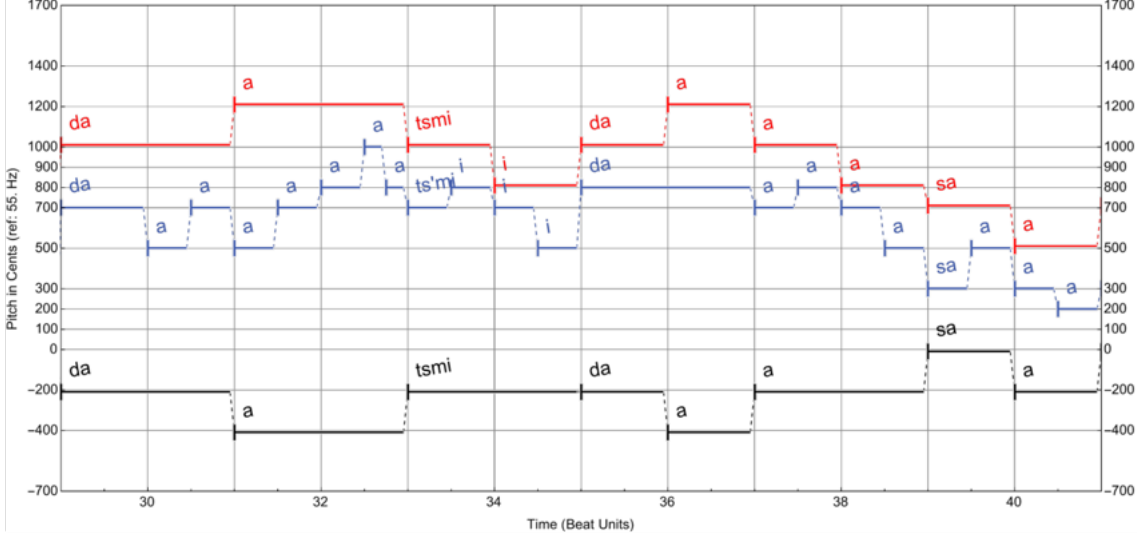
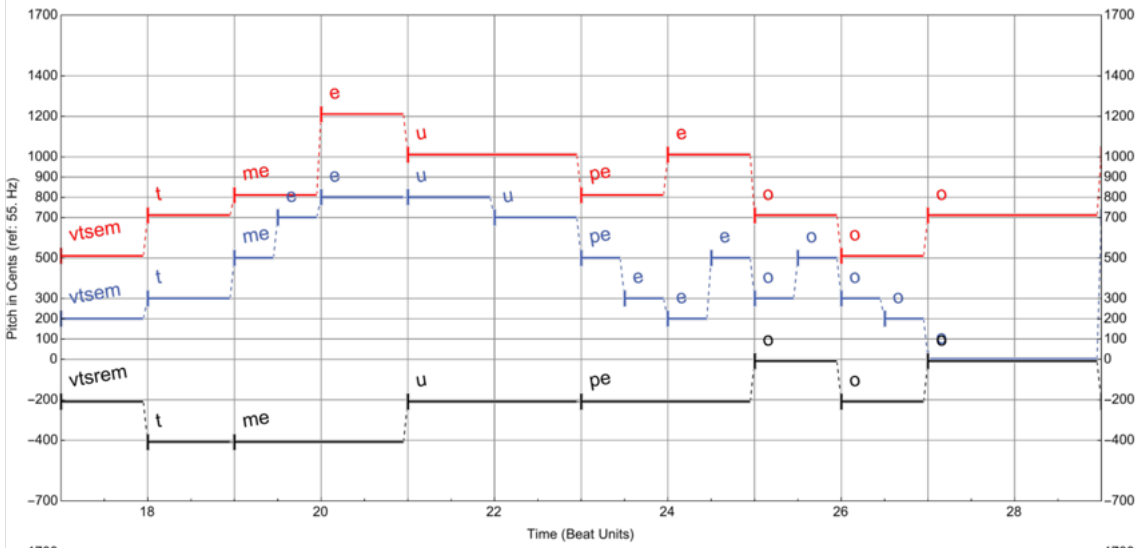
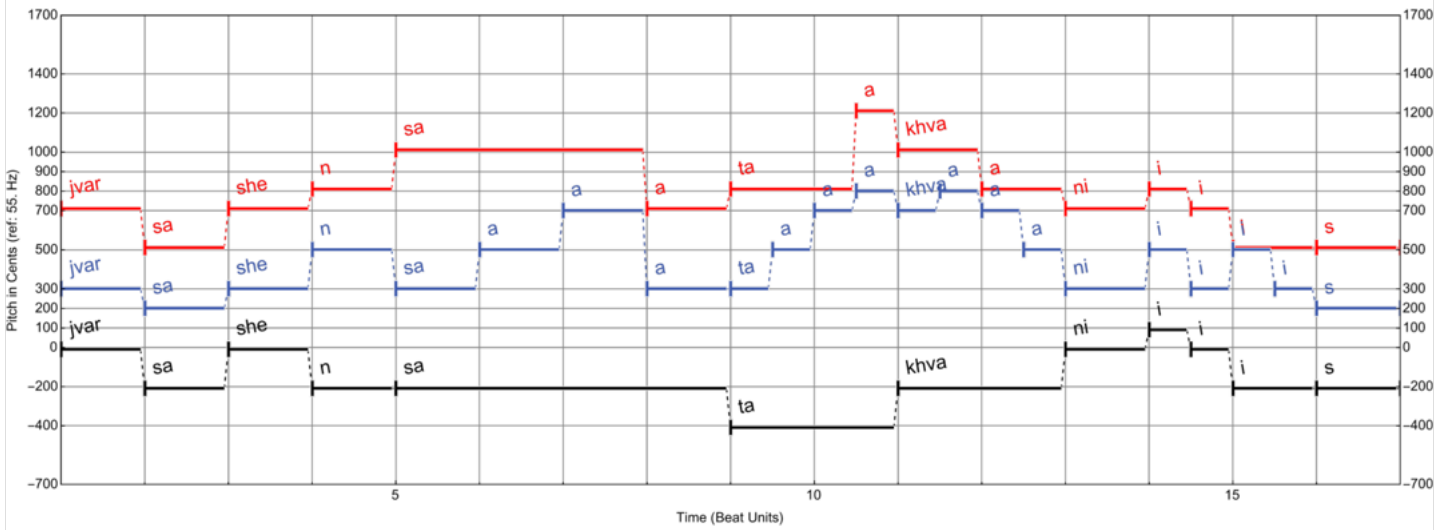

jvar sa she n sa a a ta a a khva a a a ni i i i s vtsem t me e e u pe e e o o o o da a a a a  
 tsmi i i i da a a a sa a a a a gdgo ma sa a a a a she e e e n sa a u u u u ga a a a lo o b t da a va a a a di i i de e e e ebt



This work is licensed under a Creative Commons Attribution International 4.0 License. © 2024 Copyright held by Frank Scherbaum.

Jvarsa Shensa (12TET) 2 of 2

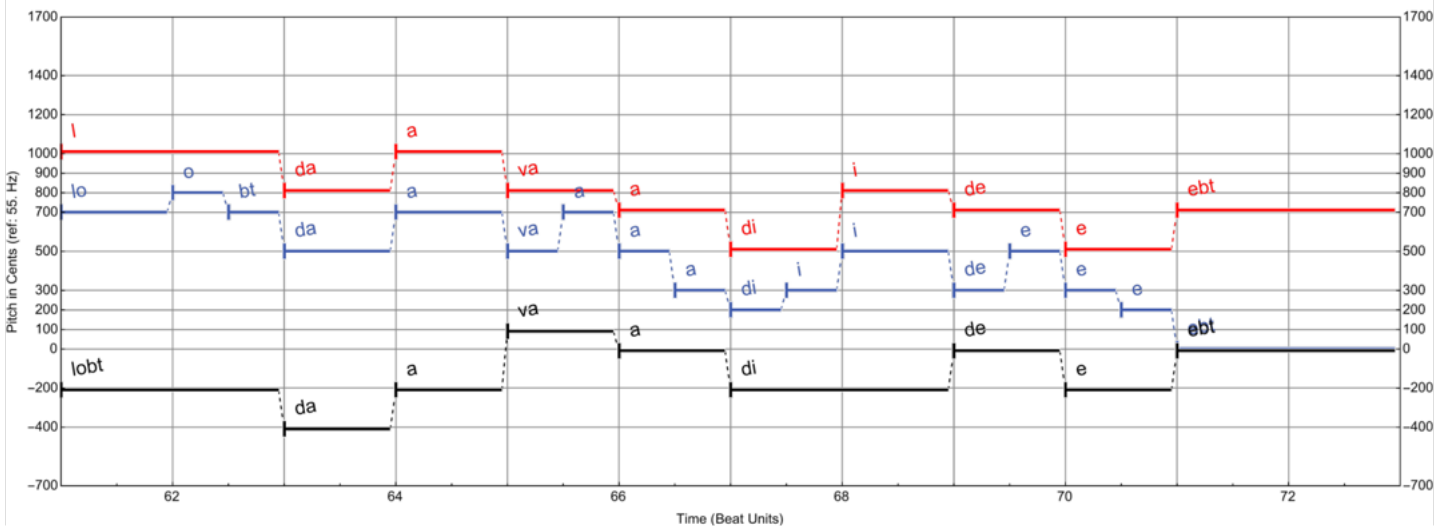
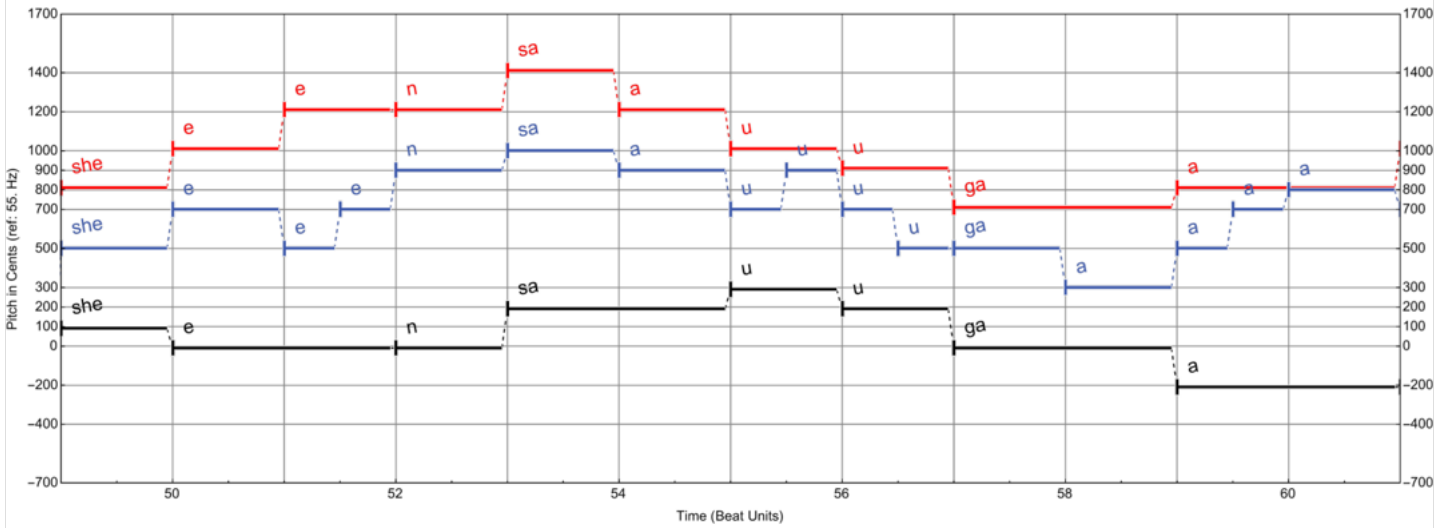
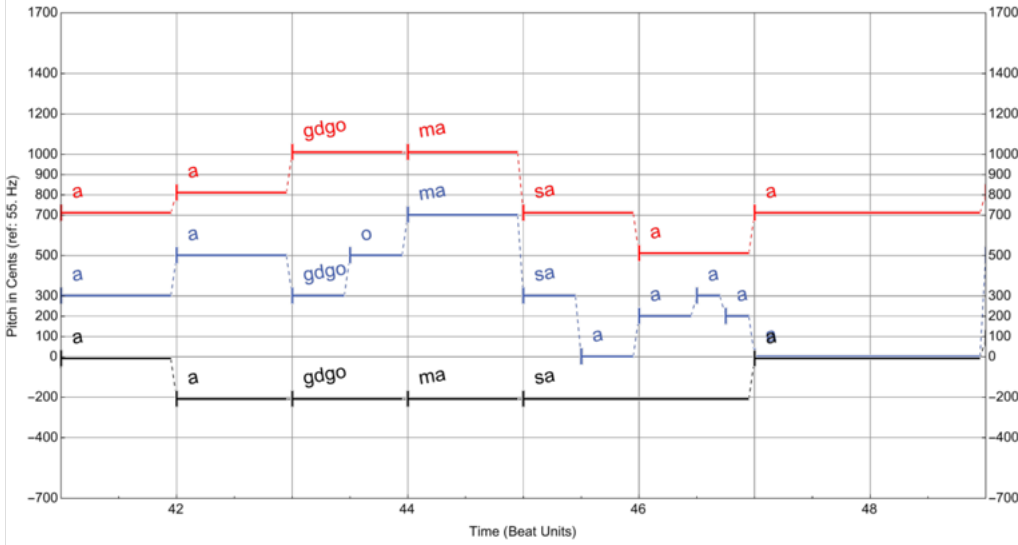

jvar sa she n sa a a ta a a khva a a a ni i i i s vtsem t me e e u u pe e e e o o o o da a a a a a  
 tsmi i i da a a a sa a a a a gdgo ma sa a a a a she e e e n sa a u u u u ga a a a lo o bt da a va a a a di i i de e e e ebt

### Kriste Aghdga (12TET)

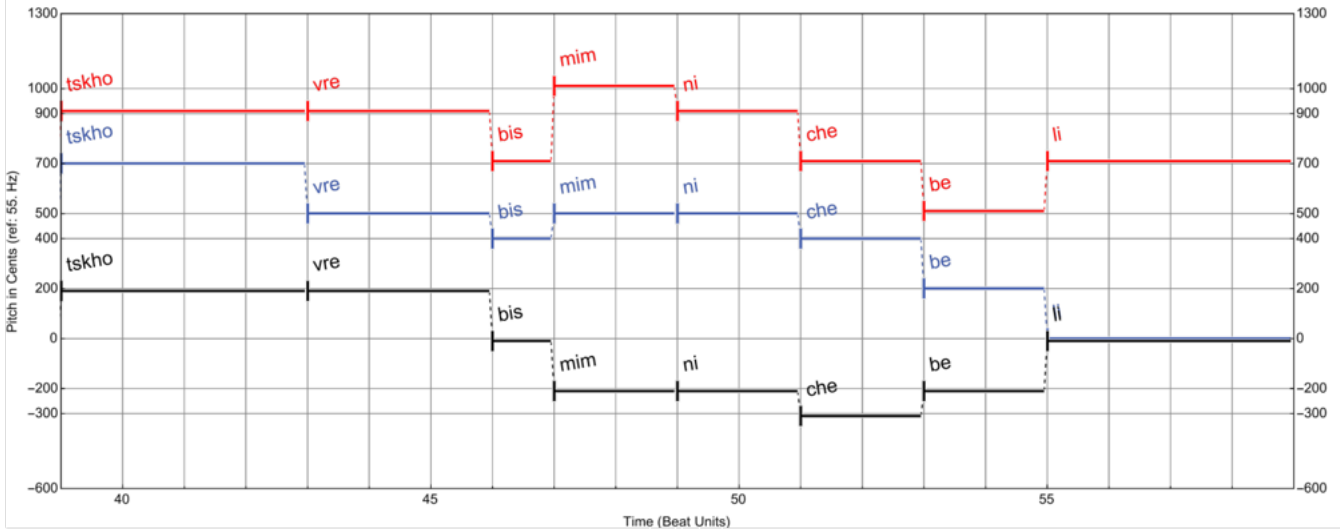
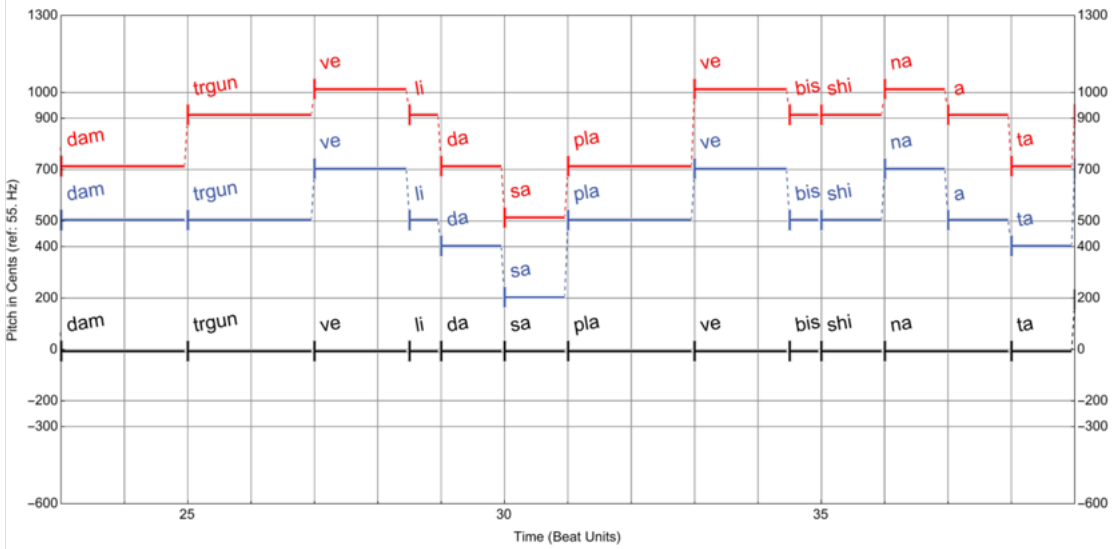
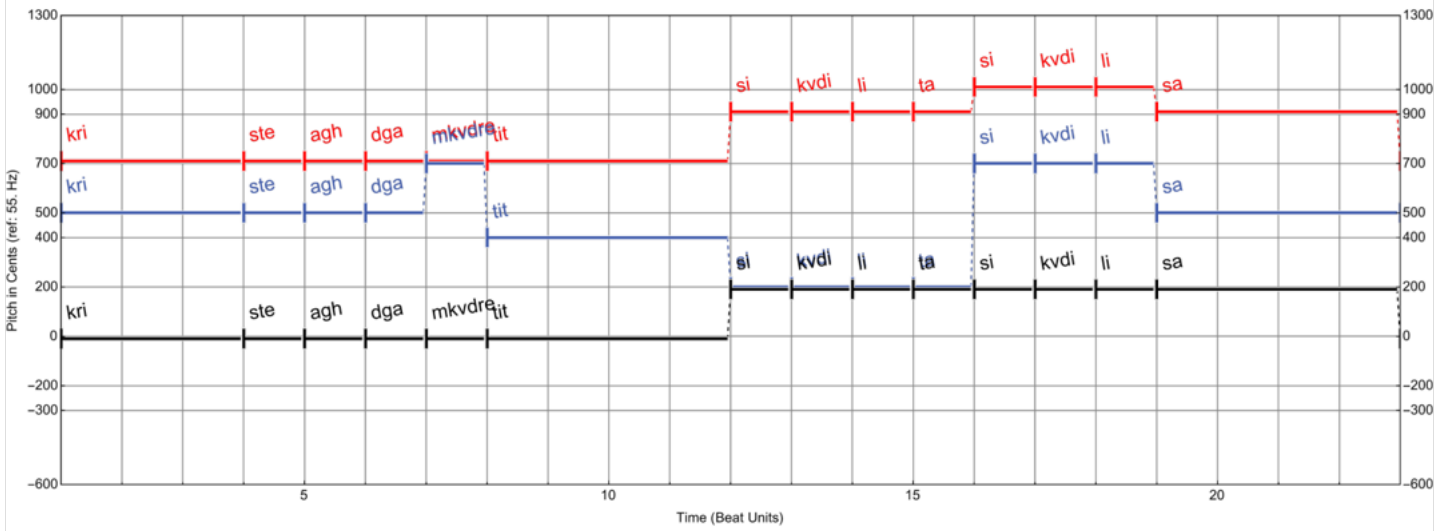

kri ste agh dga mkvdre tit si kvdi li ta si kvdi li sa dam trgun ve li da sa pla ve bis shi na a ta tskho vre bis mim ni che be li



This work is licensed under a Creative Commons Attribution International 4.0 License. © 2024 Copyright held by Frank Scherbaum.



### Lale (12TET)

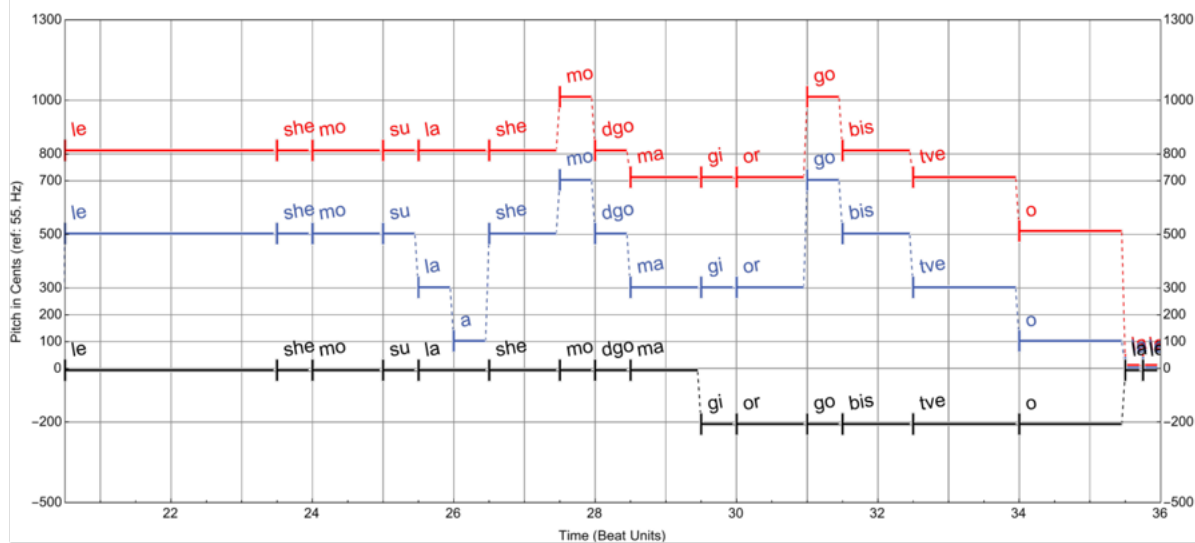
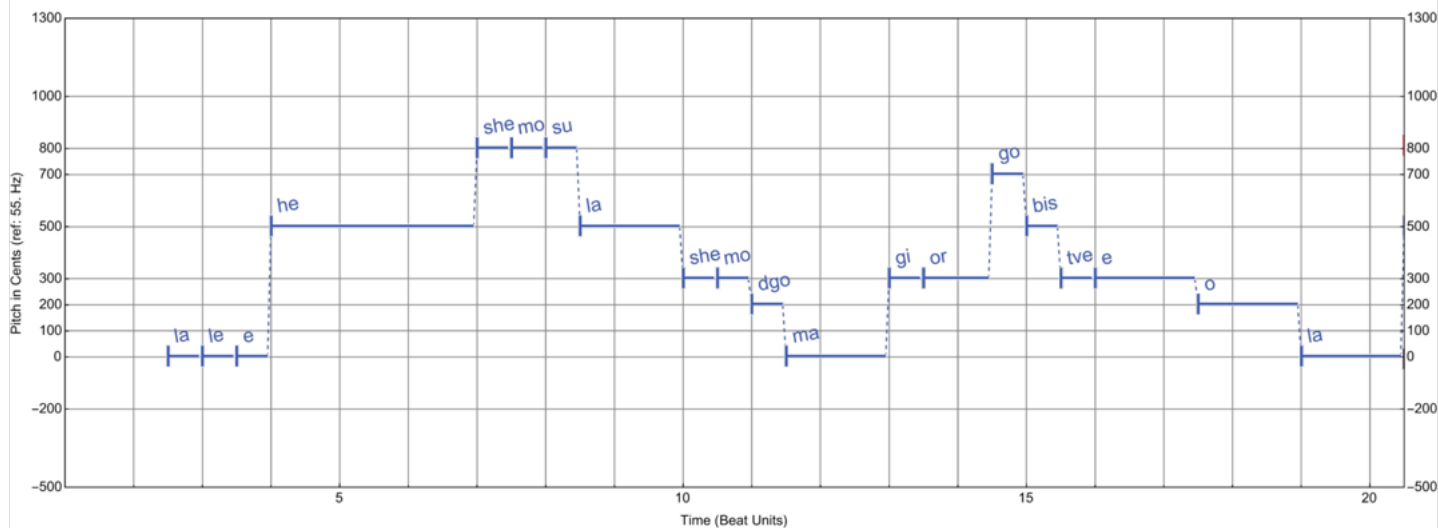

1. la le e he she mo su la she mo dgo ma gi or go bis tve e o la le
2. ra to mar cha mo i va re qve rom da gi ba a re la le
3. mi tom ar cha mo i vas re koc nas da ve ma a le la le
4. gha mis tor met sa a tam de la mpa va bri a a le la le
5. lam pa rom ga mo me li a chra qi va bar ba a re la le
6. ge lo di da ar mo khve di crem lic bec ri vhga a re la le



This work is licensed under a Creative Commons Attribution International 4.0 License. © 2024 Copyright held by Frank Scherbaum.

### Lazare (12TET)

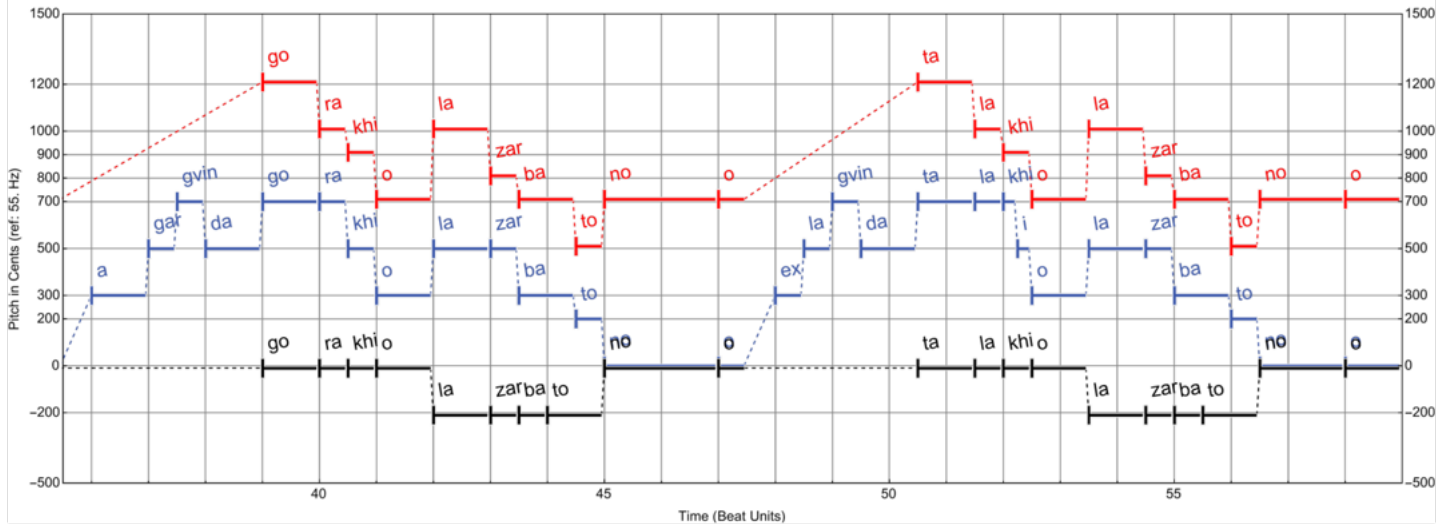
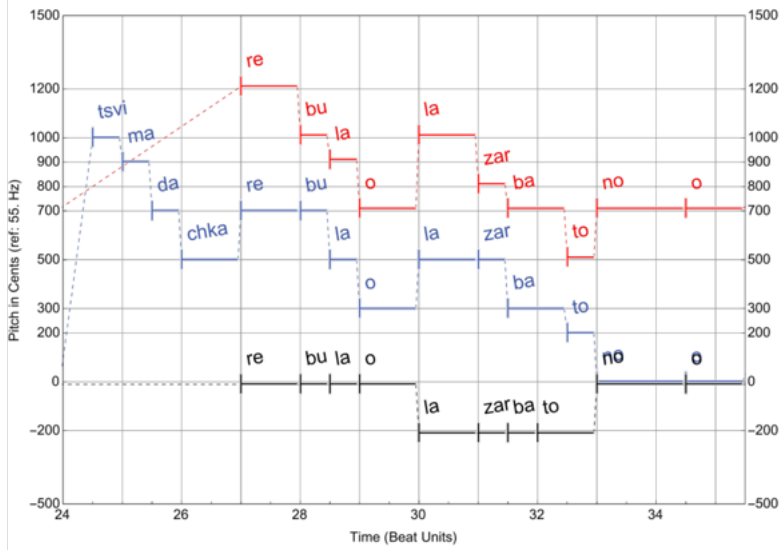
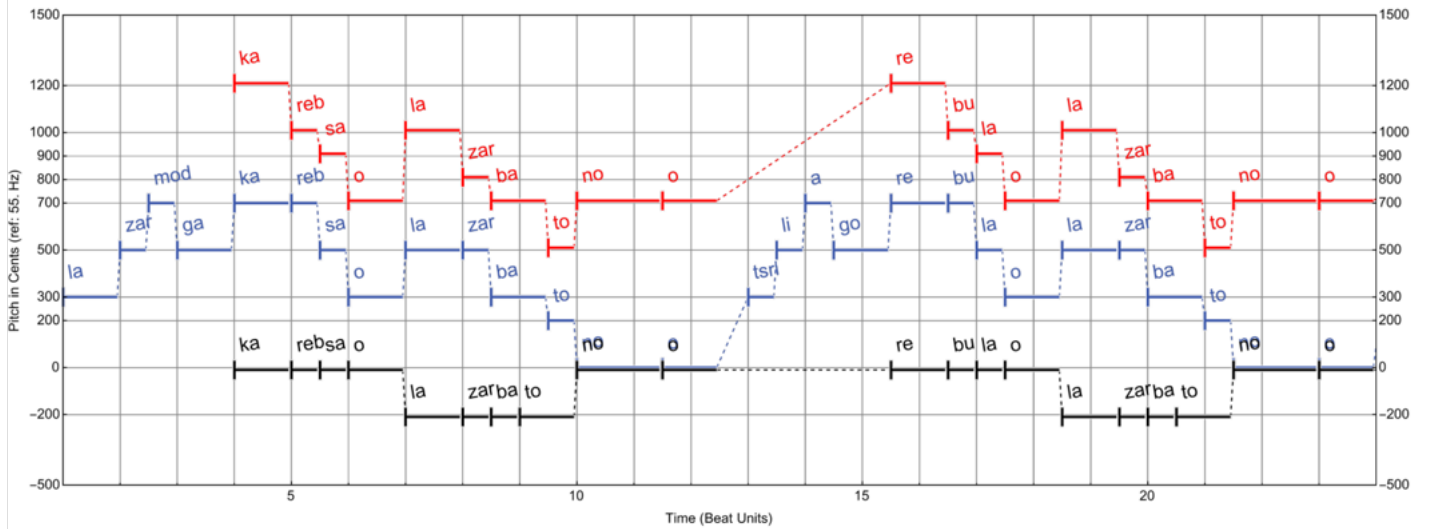

la zar mod ga ka reb sa o la zar ba to no  
 ab ri a lebs tva leb sa o la zar ba to no  
 tsri li a go re bu la o la zar ba to no  
 ax e li a li a o la zar ba to no  
 tet ri txa da ti ka ni o la zar ba to no  
 tsvi ma da chka re bu la o la zar ba to no  
 shen rat mo gi tsqe ni a o la zar ba to no  
 shen tvie mo gvir tme vi a o la zar ba to no  
 a gar gvin da go ra khi o la zar ba to no  
 ex la gvin da ta la khi i o la zar ba to no

### Lazhgvasht (12TET)

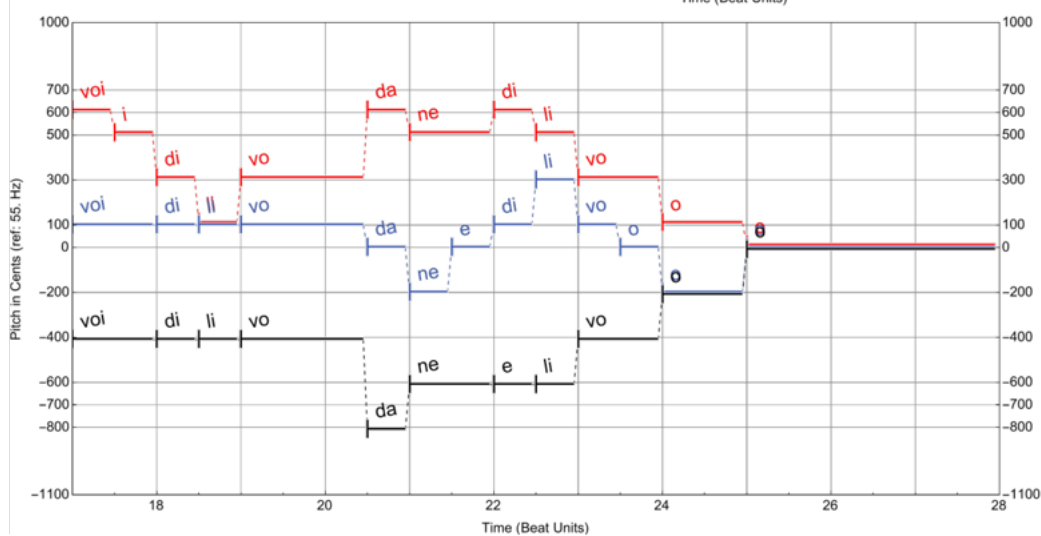
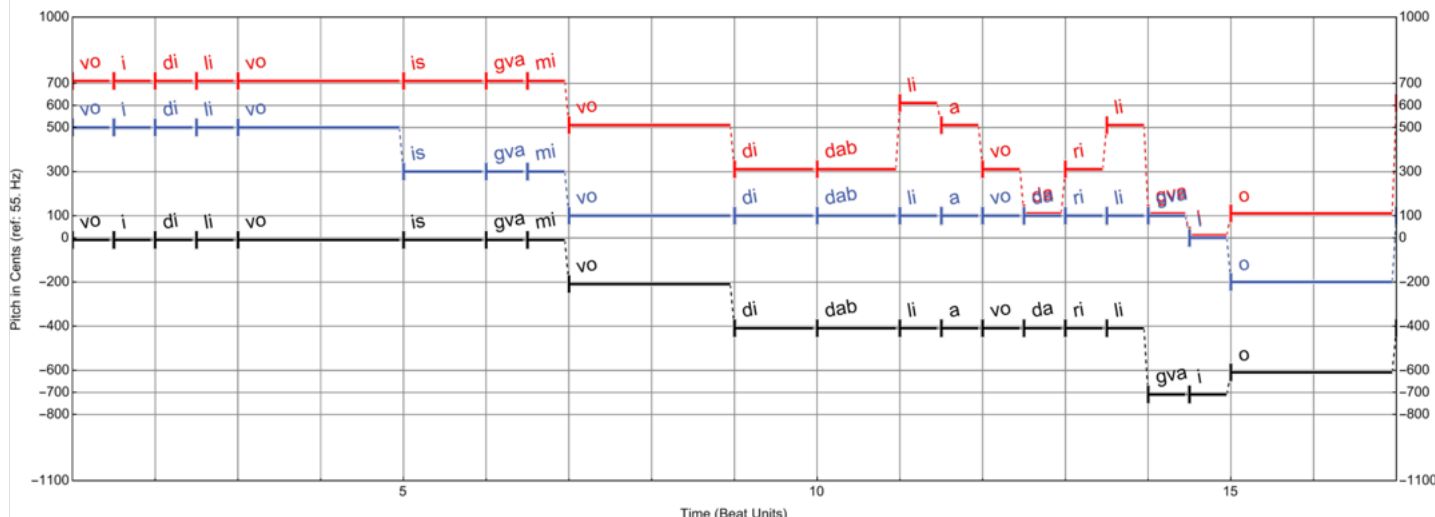

vo i di li vo is gva mi vo di dab li a vo da ri li gva i o voi di li vo da ne e di li vo o o is gva mi vo sam ka  
 li a vo da ri li gva i vo ghai na i vo djir dagh li a vo da sga sh la l gena di muchv ri vo kha giankh li a vo  
 da shvi m o k vrashi

### Lile (12TET)

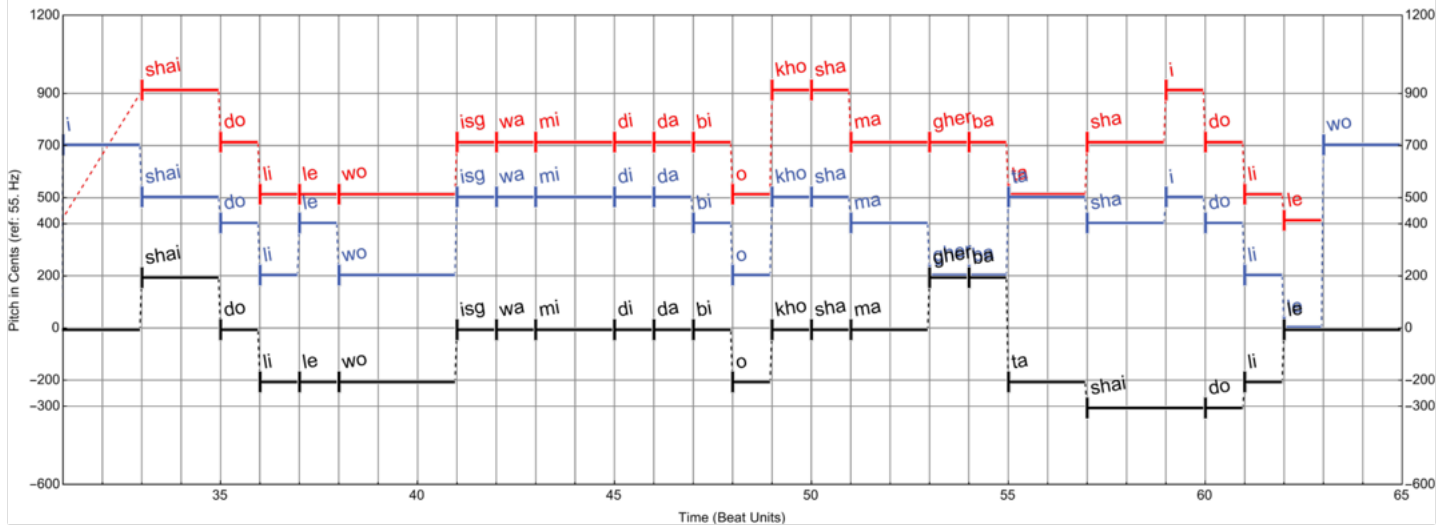
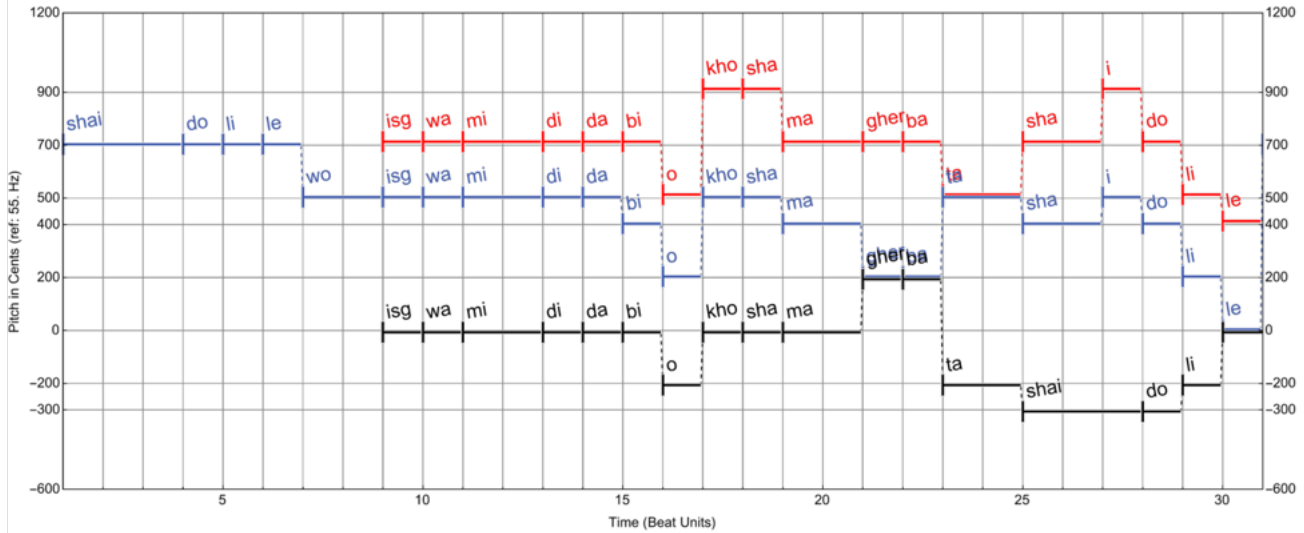

shai do li le wo isg wa mi di da bi o kho sha ma gher ba ta sha i do li le  
 i shai do li le wo isg wa mi di da bi o kho sha ma gher ba ta sha i do li le wo



This work is licensed under a Creative Commons Attribution International 4.0 License. © 2024 Copyright held by Frank Scherbaum.

### Maspindzelsa (12TET)

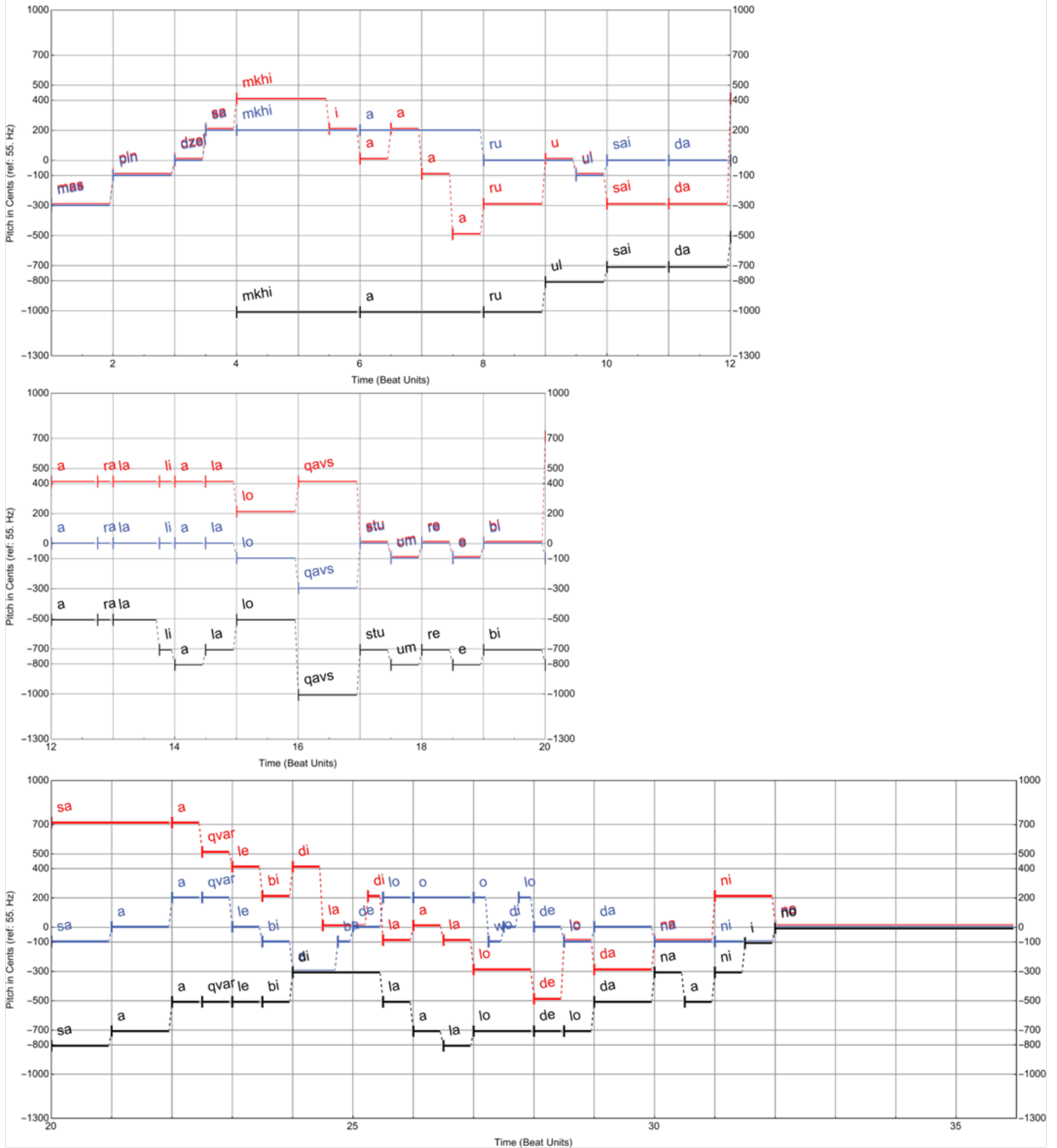

1. mas pin dze sa mkhi i a a a a ru u ul sai da a rala li a la lo qavs stu um re e bi sa a qvar le bi  
(di la di la a la lo) ⇔ (a ba de lo wo di lo) de lo da na ni no
2. ghmer to nu ras nu u u u u u mo o o shli da a rala li a la lo rats ro om hqa av des sa a qvar le bi  
(di la di la a la lo) ⇔ (a ba de lo wo di lo) de lo da na ni no
3. gam khi a rul di it bu u u u kha a a ro da a rala li a la lo gul ca a kve e u li i nu kha ro  
(di la di la a la lo) ⇔ (a ba de lo wo di lo) de lo da na ni no

Top and bass: di la di la a la lo  
Middle: (a ba de lo wo di lo)



### Misdevs Mela Lomsa (12TET)

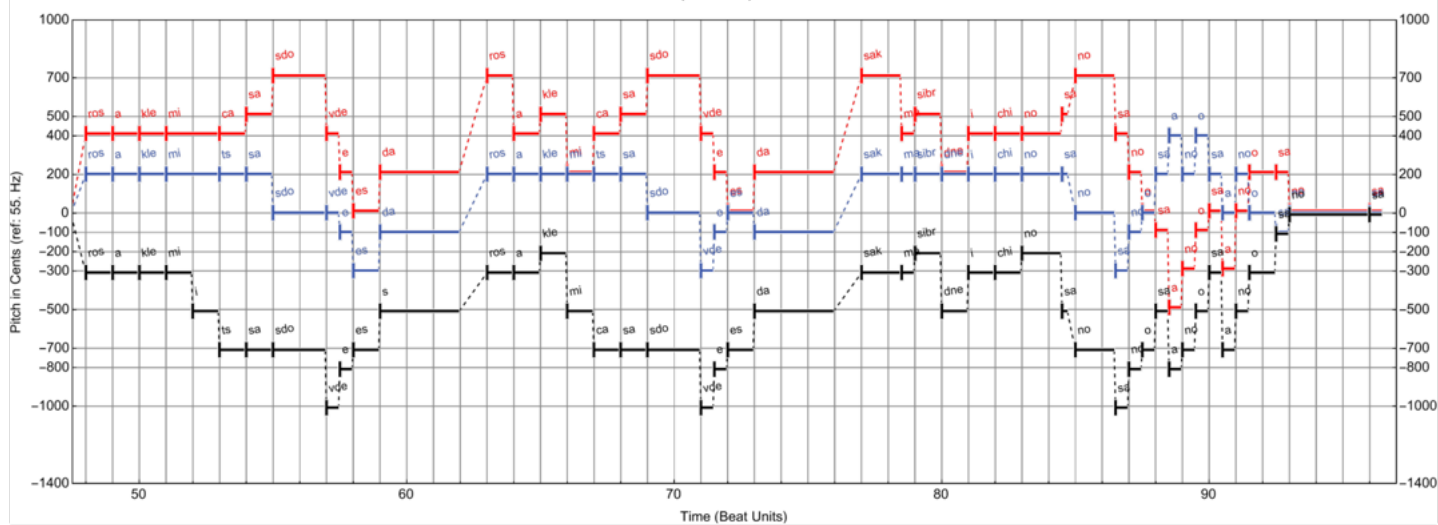
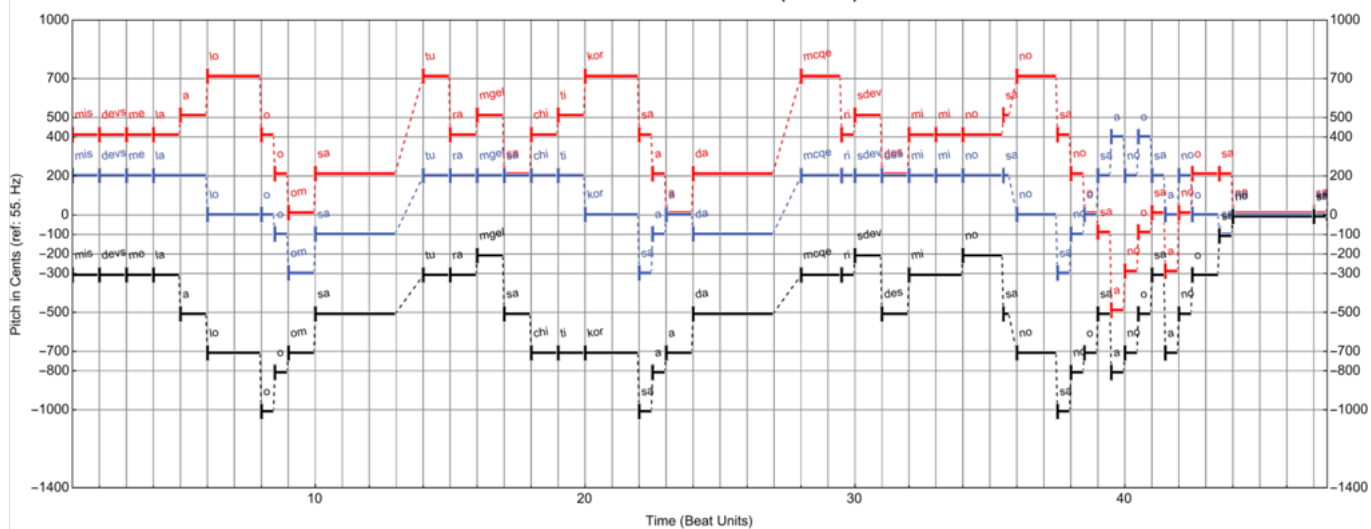

mis devš me la lo o o om sa tu ra mgel sa chi ti kor sa a a da mcqe ri sdev des mi mi no sa  
 no sa no o sa a no o sa a no o sa no sa  
 ros a kle mi ts sa sdo vde e es da ros a kle mi ts sa sdo vde e es da sak ma sibr dne i chi no sa  
 no sa no o sa a no o sa a no o sa no sa



This work is licensed under a Creative Commons Attribution International 4.0 License. © 2024 Copyright held by Frank Scherbaum.

### Mze Shina (12TET)

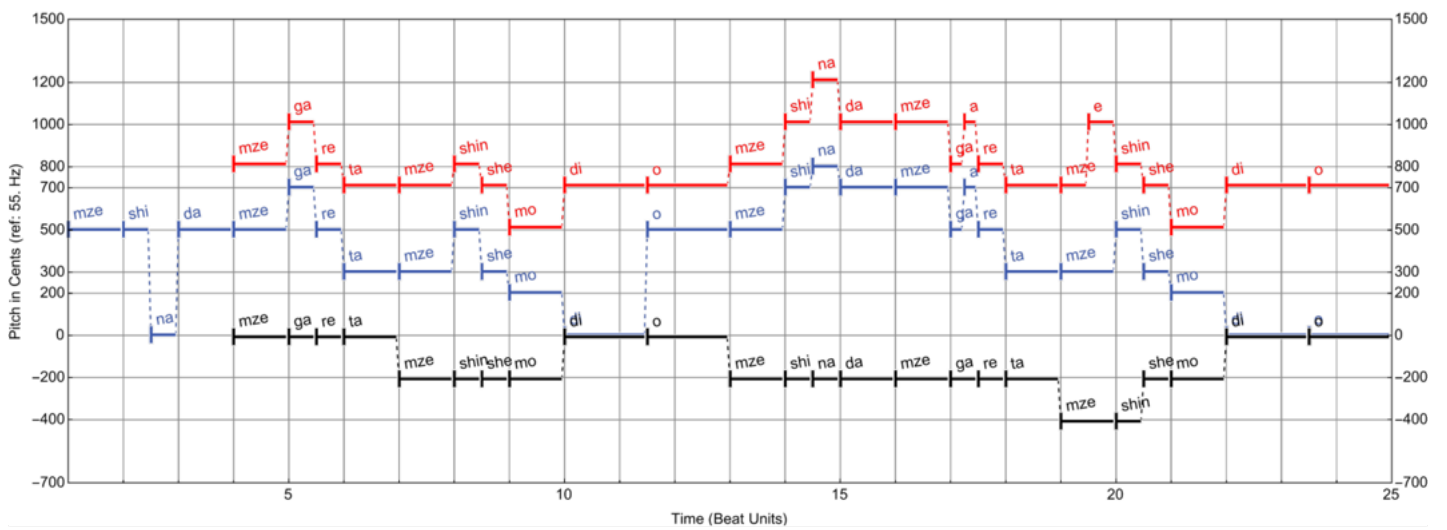

mze shi na da mze ga re ta mze shin she mo di o  
 chven va zhi da gvba de bi a mze shin she mo di o  
 va zhis ma ma shin ar a ris mze shin she mo di o  
 ka laks a ris akn vnist vi na mze shin she mo di o  
 mze dats va da mtva re sho ba mze shin she mo di o



This work is licensed under a Creative Commons Attribution International 4.0 License. © 2024 Copyright held by Frank Scherbaum.



### Nana (12TET)

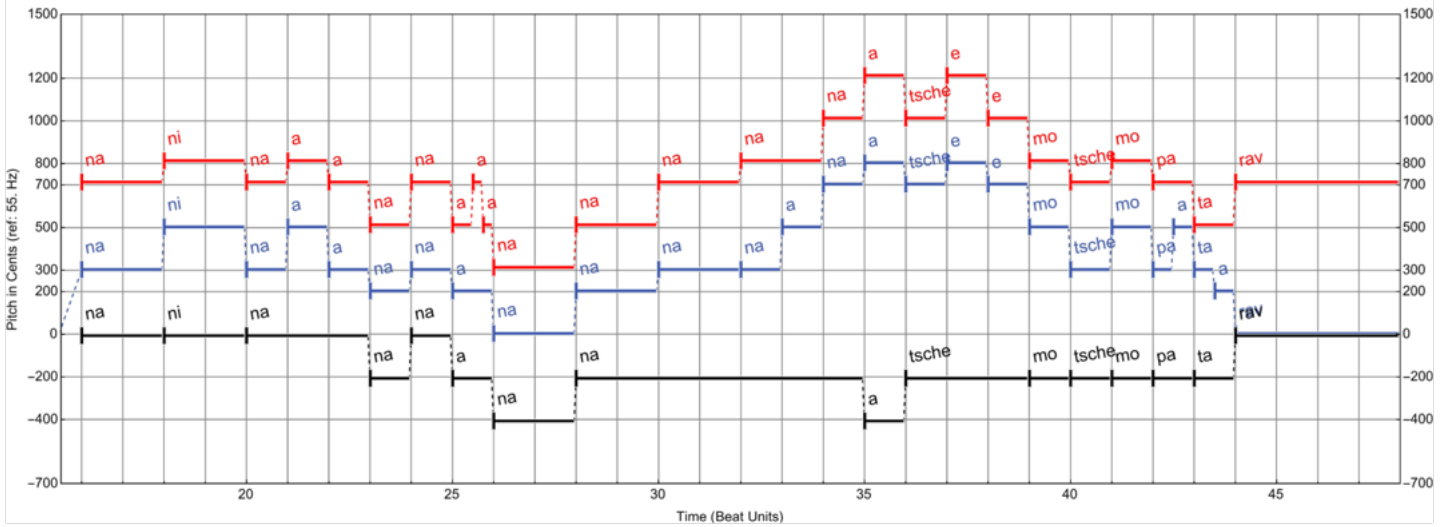
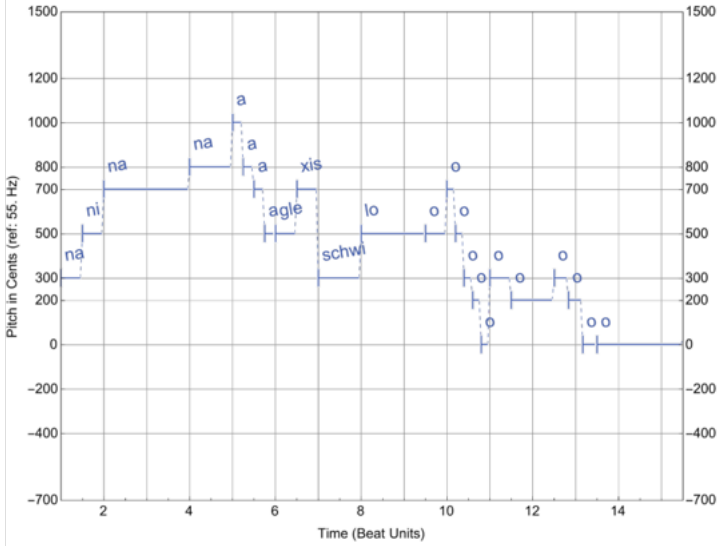

na ni na na a a a a gle xis schwi lo o o o o o o o o o o o o

na ni na a a na na a na na na a na a tsche e e mo tsche mo pa ta a rav

 This work is licensed under a Creative Commons Attribution International 4.0 License. © 2024 Copyright held by Frank Scherbaum.

### Nana (12TET)

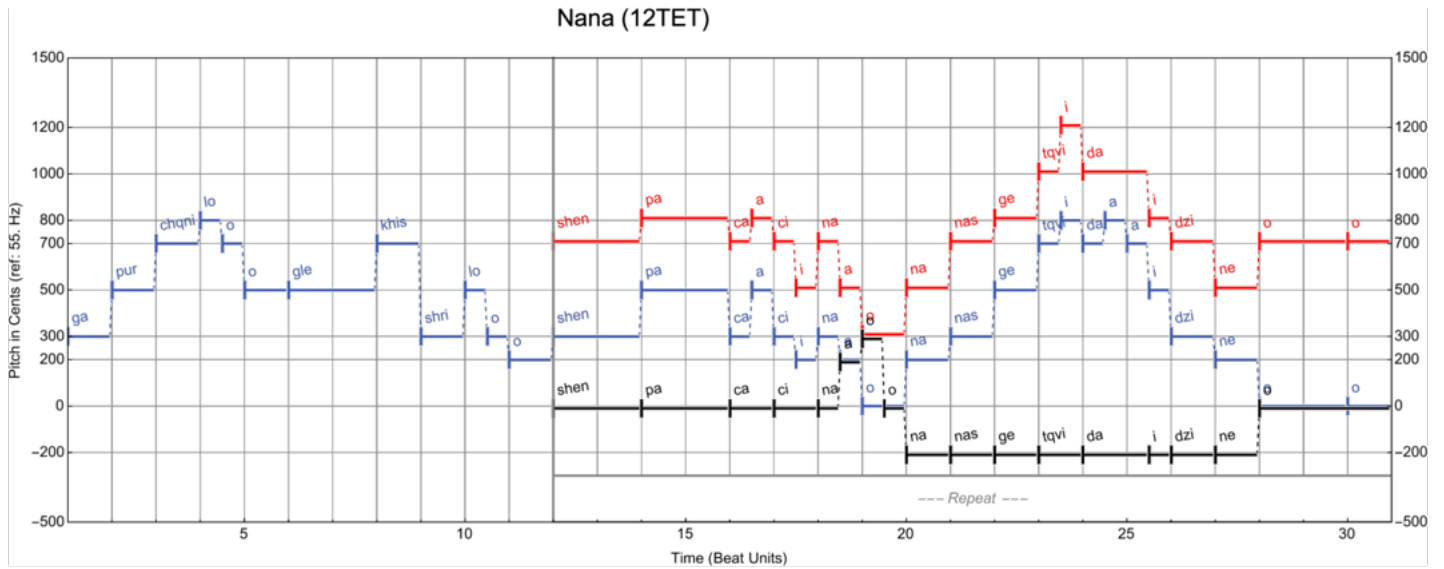

1. ga pur chqni lo o o gle khis shri lo o o shen pa ca a ci i na a o na nas ge tqvi i da a a i dzi ne o o
2. a gre tkbi la a ad u dar de la a ad ram da ga a dzi i na a o na nas ge tqvi i da a a i dzi ne o o
3. de dis mker dsa a a mi gig ni a a a shen tkbi li i bi i na a o na nas ge tqvi i da a a i dzi ne o o
4. da i dzi ne e e i av na a a a var do na a ni i na a o na nas ge tqvi i da a a i dzi ne o o
5. shens vaj ka co o o bas mo mas cre e ebs me ghvtis msho o be e li i o na nas ge tqvi i da a a i dzi ne o o



This work is licensed under a Creative Commons Attribution International 4.0 License. © 2024 Copyright held by Frank Scherbaum.

### Nanina (12TET)

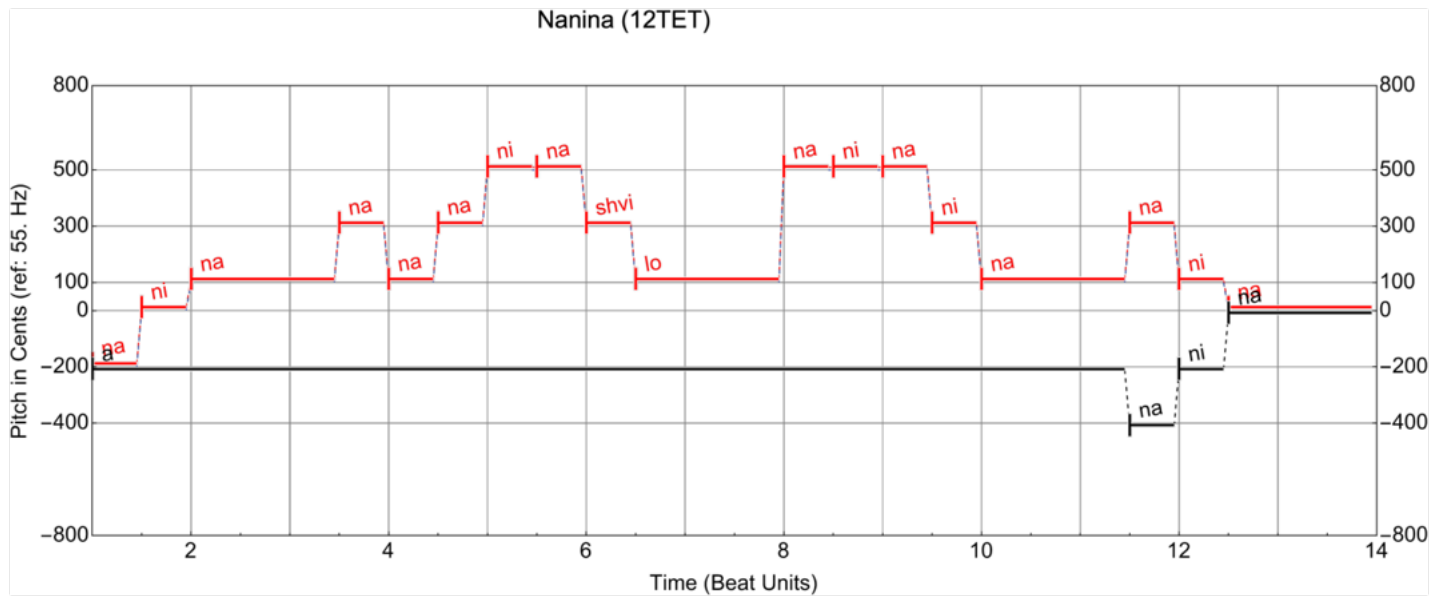

1. na ni na na na na ni shvi lo na ni na ni na na ni na
2. a ru ru cha mo sti ro da shvi lo de das na ni na un do da
3. shens ga kha re bas mo ma strebs shvi lo ma ri am ghvtis sho be li o
4. na ni na na na na ni na shvi lo na ni na ni na na ni na



This work is licensed under a Creative Commons Attribution International 4.0 License. © 2024 Copyright held by Frank Scherbaum.

### Naninada Batonebo (12TET)

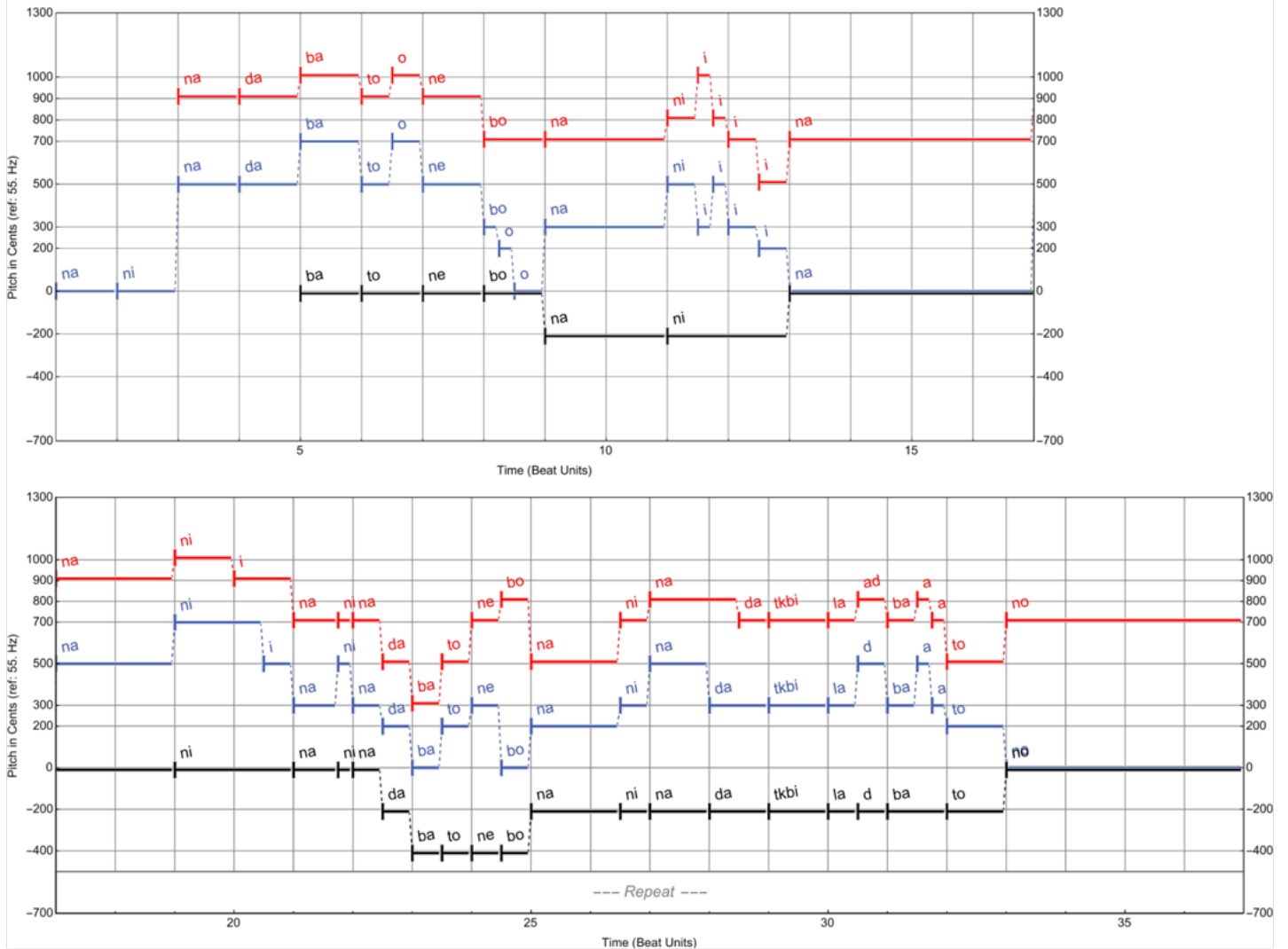

1. na ni na da ba to o ne bo o o na ni i i i i na ||: na ni i na ni na da ba to ne bo na ni na da tkbi la d ba a a to no :||
2. tkve ni gza da i lo o tse ba a a na ni i i i i na ||: na ni i na ni na da ba to ne bo na ni na da tkbi la d ba a a to no :||
3. tkven sa gza sa vu pe en va rdsa a a na ni i i i i na ||: na ni i na ni na da ba to ne bo na ni na da tkbi la d ba a a to no :||
4. tkve ni gza ga khan re e bu la a a na ni i i i i na ||: na ni i na ni na da ba to ne bo na ni na da tkbi la d ba a a to no :||



This work is licensed under a Creative Commons Attribution International 4.0 License. © 2024 Copyright held by Frank Scherbaum.

### Ortameluri (12TET)

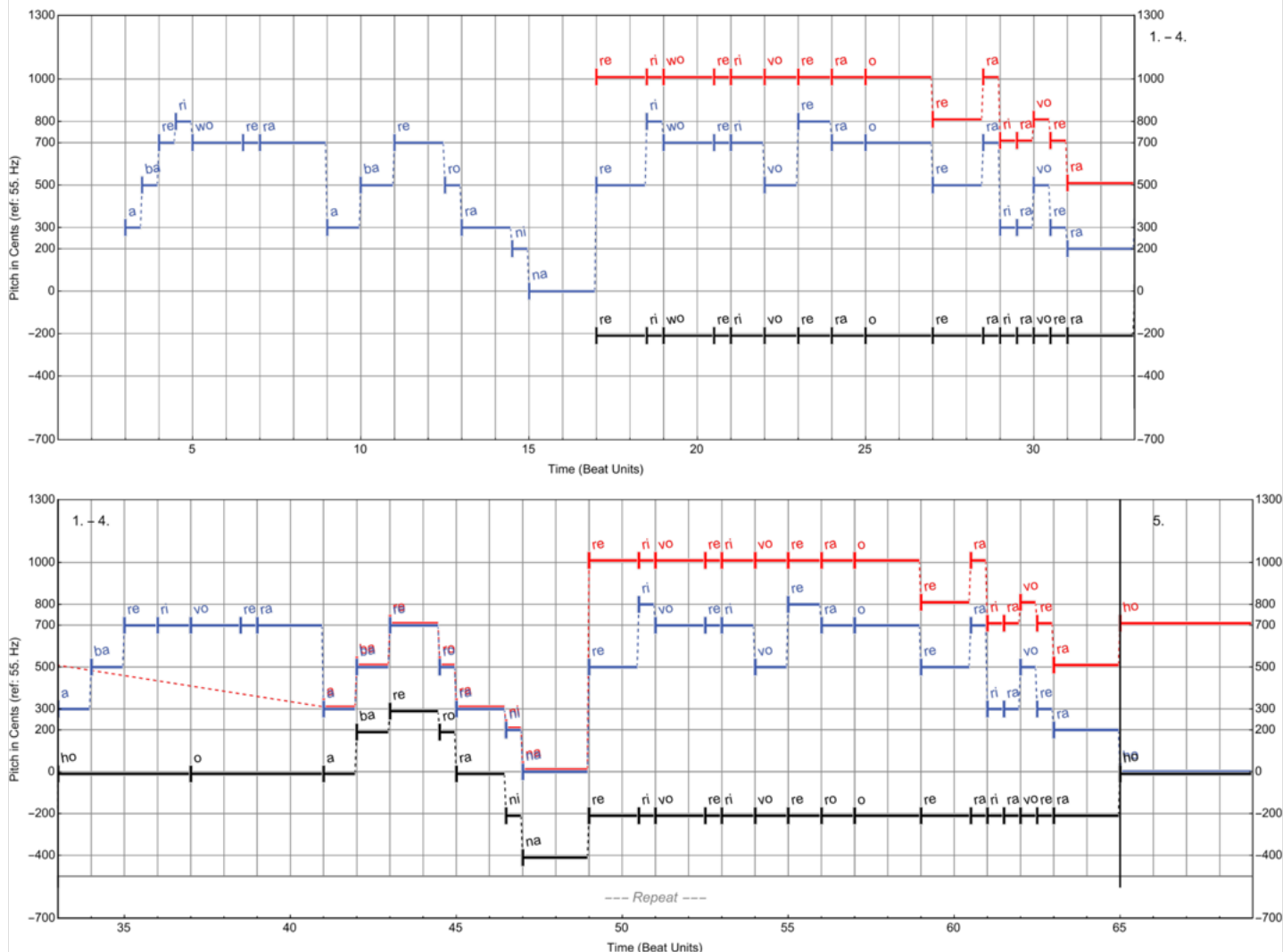

a ba re ri wo re ra a ba re ro ra ni na  
 re ri wo re ri vo re ra o re ra ri ra vo re ra

1. a ba re ri vo re ra a ba re ro ra ni na re ri vo re ri vo re ra o re ra ri ra vo re ra
  2. tsu tu so plis stum re bivart a ba re ro ra ni na chven tsa valt da skhva da che ba o re ra ri ra vo re ra
  3. tu er ta ma nets ar varkharebt a ba re ro ra ni na a mis me ti ra sheg vrche ba o re ra ri ra vo re ra
  4. a ba re ri vo re ra a ba re ro ra ni na re ri vo re ri vo re ra o re ra ri ra vo re ra
- ho



This work is licensed under a Creative Commons Attribution International 4.0 License. © 2024 Copyright held by Frank Scherbaum.

### Samshoblo (12TET)

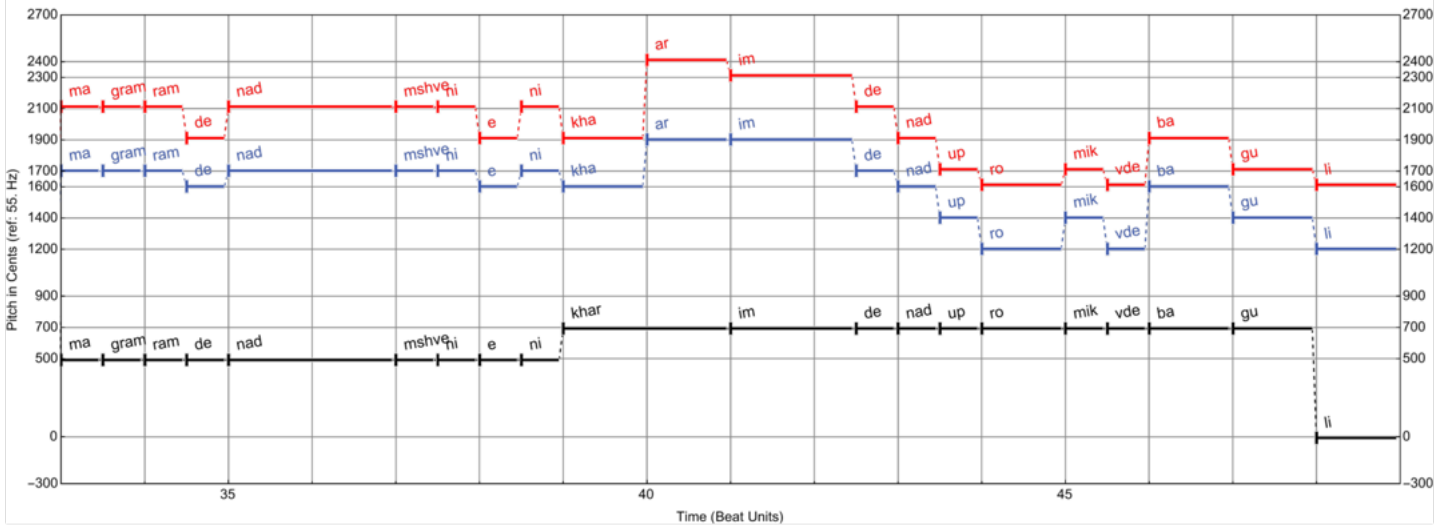
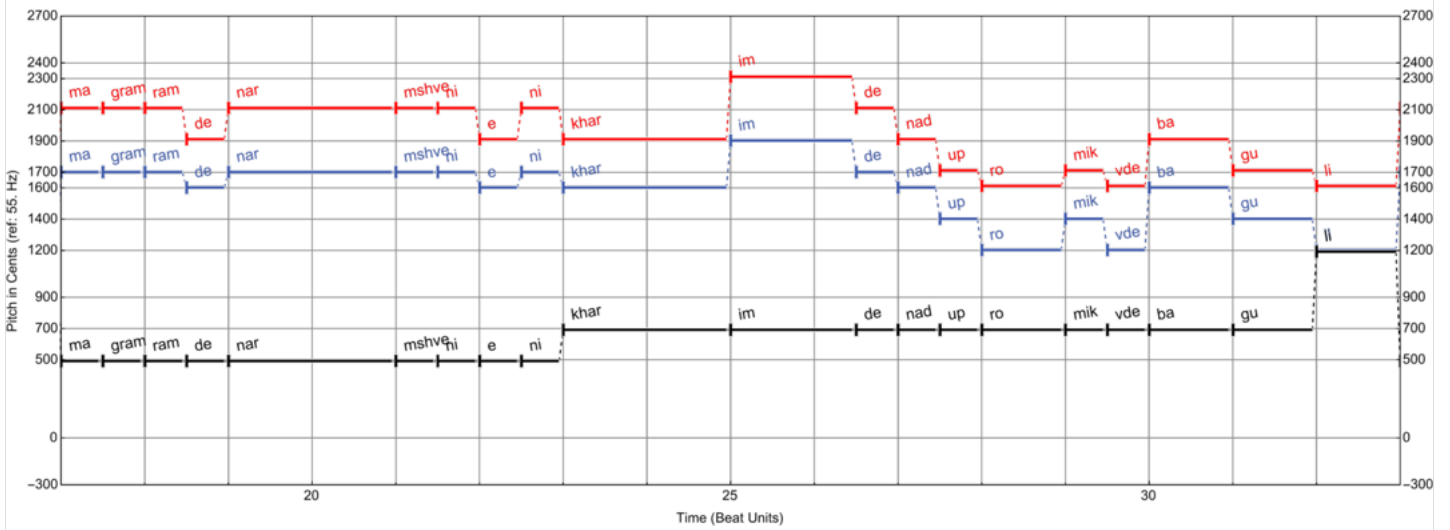
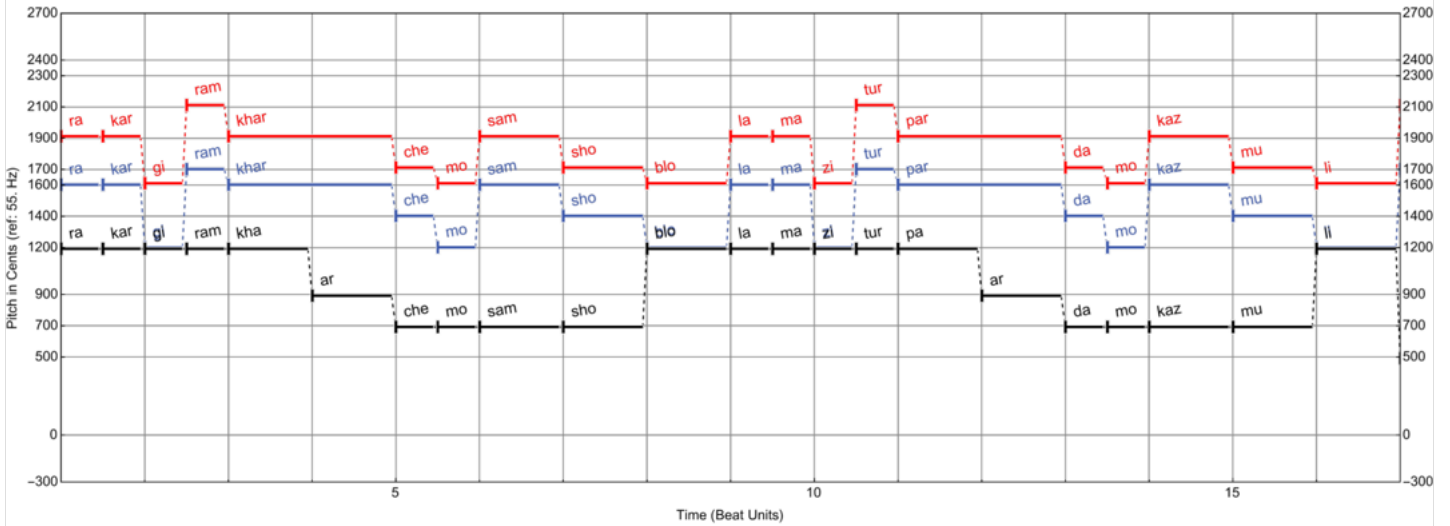

1. ra kar gi ram khar che mo sam sho blo la ma zi tur par da mo kaz mu li  
 ma gram ram de nar mshve ni e ni khar im de nad up ro mik vde ba gu li  
 ma gram ram de nad mshve ni e ni kha ar im de nad up ro mik vde ba gu li
2. ra da grche ni a kvlav sa na tre li ghvtis gan ra ar gakvs mo ma de bu li  
 ma gram ram de nad mad lit sav se khar im de nad up ro mik vde ba gu li  
 ma gram ram de nad mad lit sav se kha ar im de nad up ro mik vde ba gu li

### Sedeko (12TET)

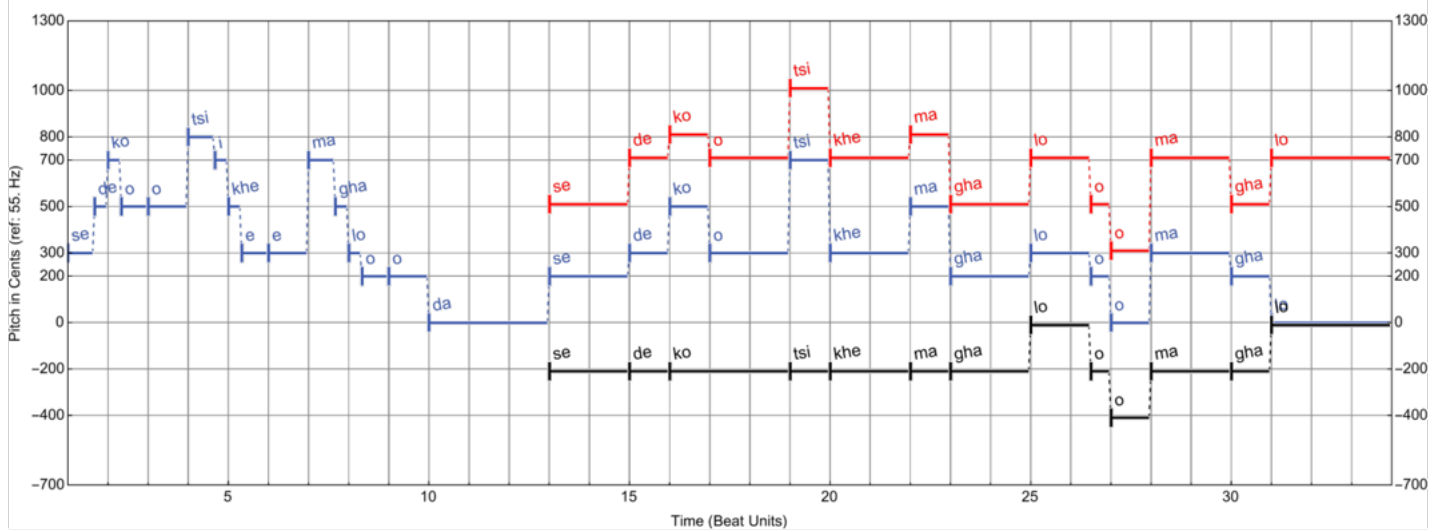

1. se de ko o tsi i khe e ma gha lo o da se de ko o tsi khe ma gha lo o o ma gha lo
2. a she ne e e bu u u lo kvi sa o o da a she ne e bu lo kvi sa o o kvi sa o
3. da di a ans she e mo o ut vli a a da da di a ans she mo ut vli a a a ut vli a
4. tu med ga a ri i kha ar dam khvdi o o da tu med ga a ri khar dam khvdi o o o dam khvdi o



This work is licensed under a Creative Commons Attribution International 4.0 License. © 2024 Copyright held by Frank Scherbaum.

Shen Xar Venakhi (12TET)

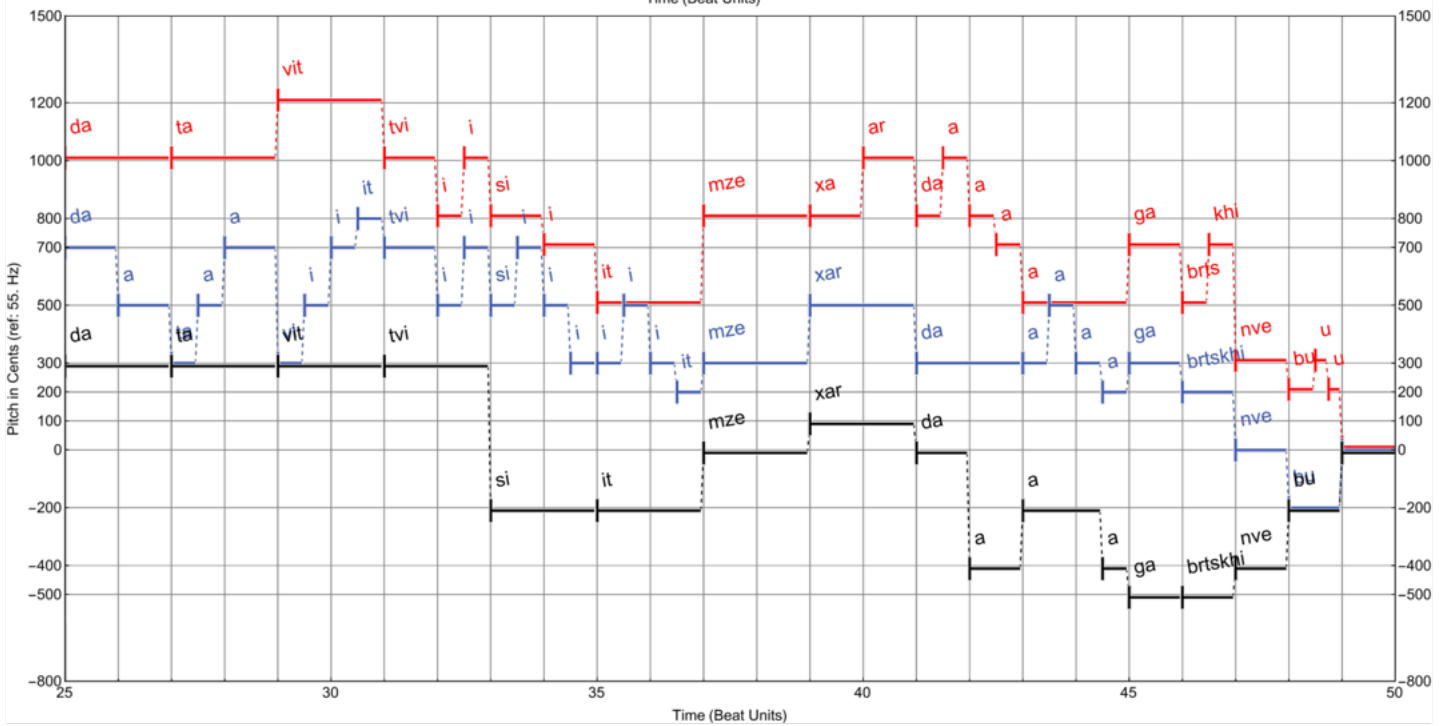
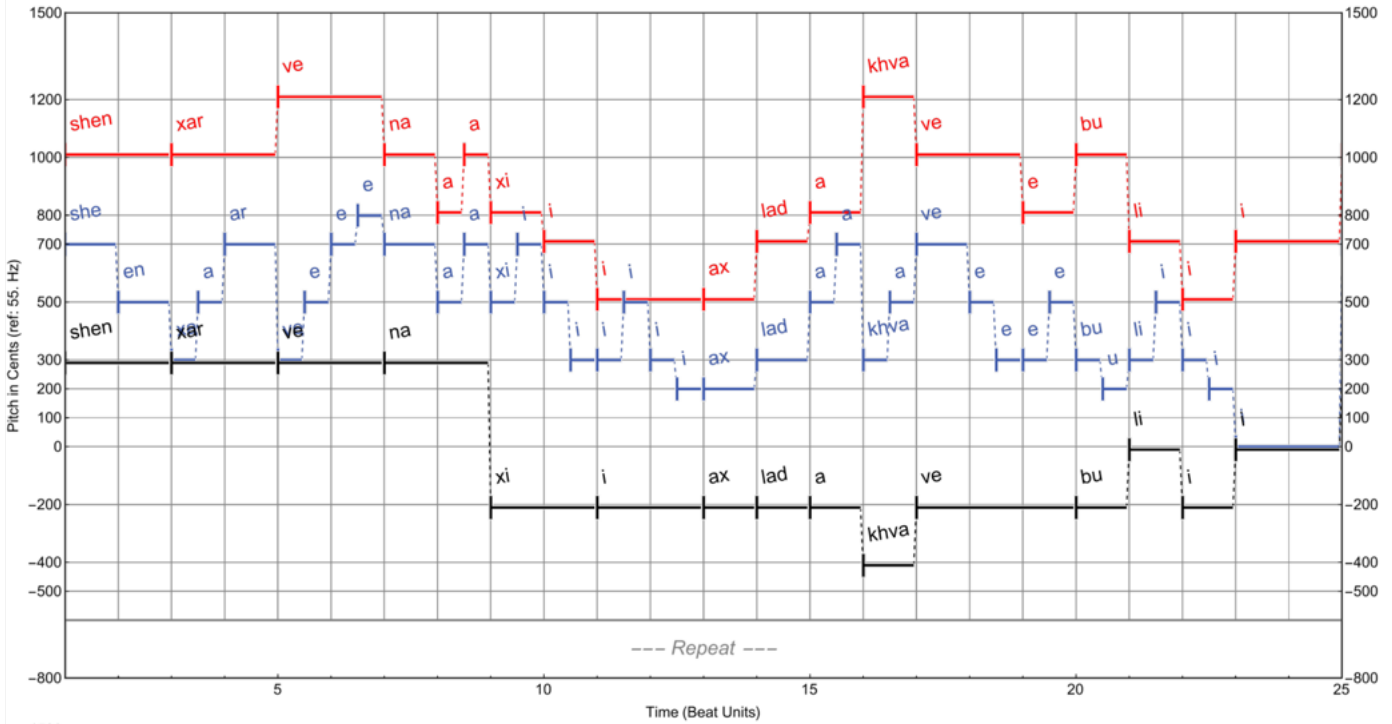

Middle voice:

she en xa a ar ve e e e na a xiiiiiii ax lad a a khva a ve e e e bu liiii  
 mo or chi i i ke e e e ti i l i i i i i i e dems shi i na a ne e e e rgu u liiii  
 da a ta a a vi i i tvi i i si i i i i i i it mze xar da a a a ga brtskhi nve bu li



This work is licensed under a Creative Commons Attribution International 4.0 License. © 2024 Copyright held by Frank Scherbaum.



### Sisa Tura (12TET)

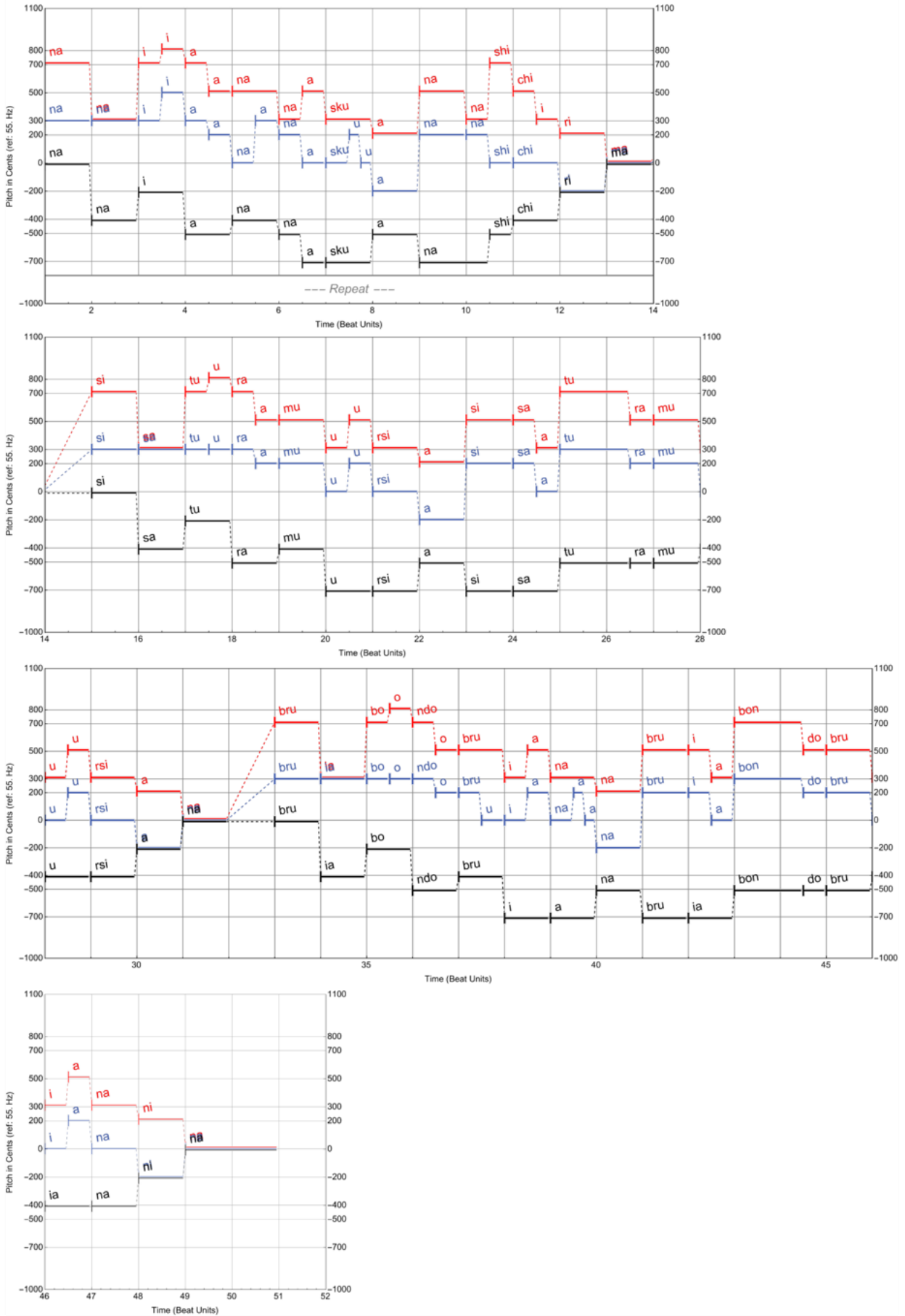

1. na na i i a na a na a sku u u a na na shi chi ri ma
2. ar kva ni i sha di i sha am ja a a nu var di shi pi ri ma
3. si sa tu u ra a mu u u rsi a si sa a tu ra mu u u rsi a na  
bru ia bo ndo bru i a na a a na bru i a bon do bru i a na ni na

### Thebrone (12TET)

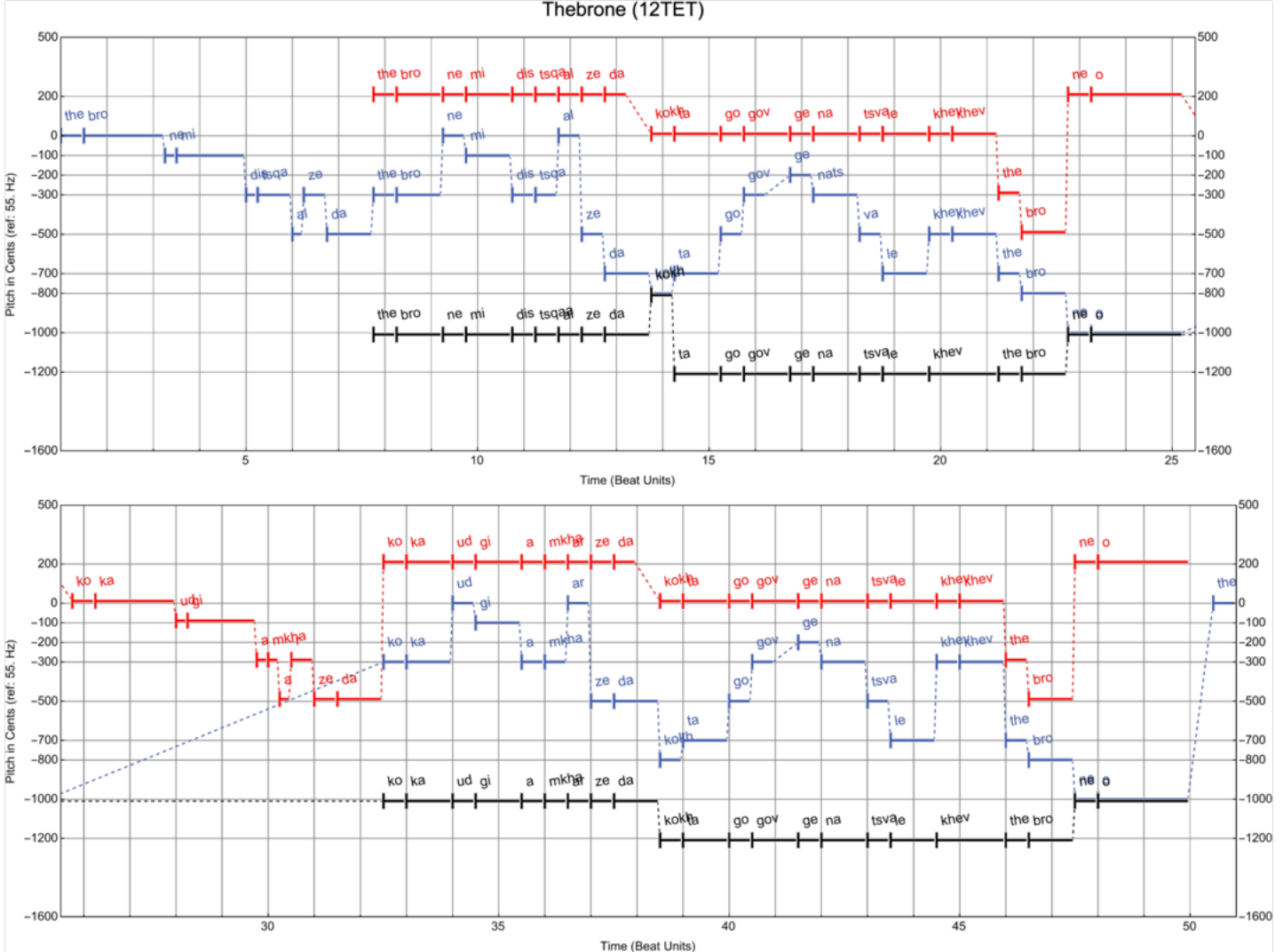

1. the bro ne mi dis tsqa al ze da the bro ne mi dis tsqa al ze da kokh ta go gov ge nats va le khev khev the bro ne o  
ko ka ud gi a mkha ar ze da ko ka ud gi a mkha ar ze da kokh ta go gov ge na tsva le khev khev the bro ne o
2. the bro nem ko ka ga a av so the bro nem ko ka ga a av so kokh ta go gov ge nats va le khev khev the bro ne o  
ik ve tsa mo tsva kva a a ze da ik ve tsa mo tsva kva a ze da kokh ta go gov ge nats va le khev khev the bro ne o
3. bi cho mo ge li tsqa al ze da bi cho mo ge li tsqa al ze da kokh ta go gov ge nats va le khev khev the bro ne o  
bich ma the bro nes a ak o tsa bich ma the bro nes a ak o tsa kokh ta go gov ge nats va le khev khev the bro ne o



This work is licensed under a Creative Commons Attribution International 4.0 License. © 2024 Copyright held by Frank Scherbaum.

Tsmindao Ghmerto (12TET)

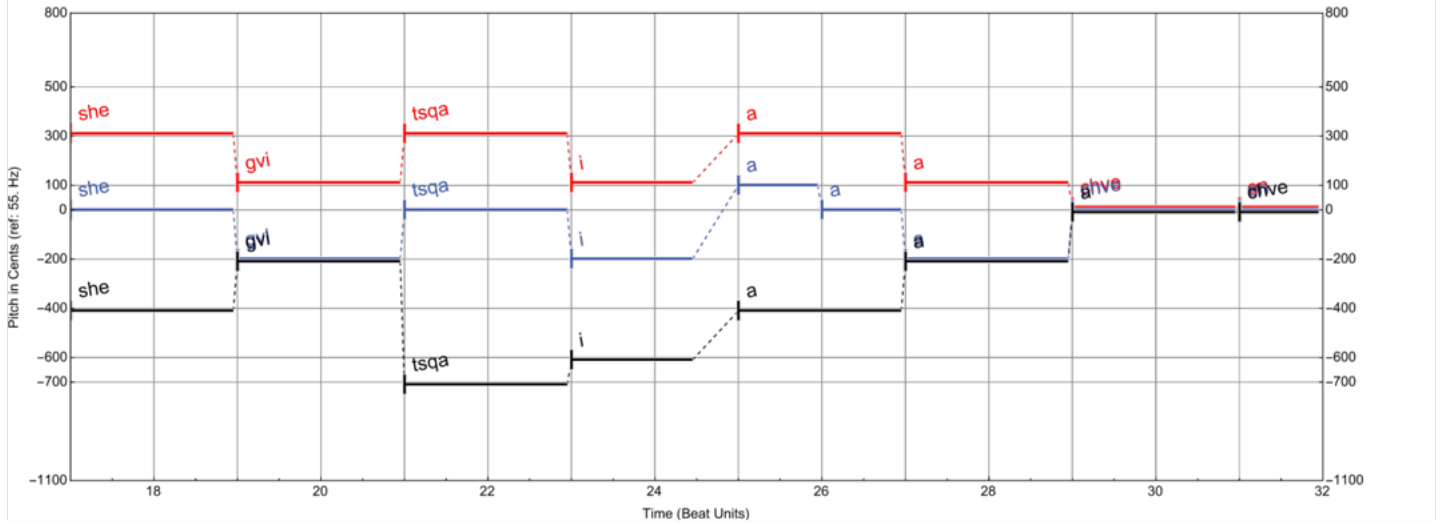
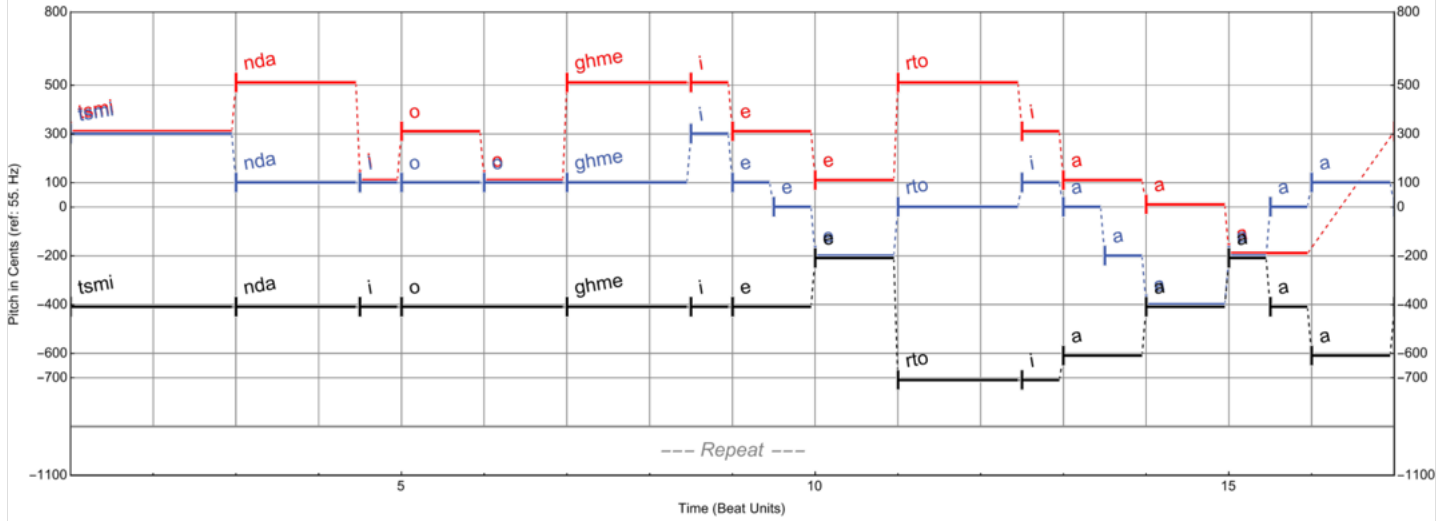

tsmi nda i o o ghme i e e e rto i a a a a a she gvi tsqa i a len chve en  
 tsmi nda i o o dzli i e e e ro i a a a a a she gvi tsqa i a len chve en  
 tsmi nda i o o u kv da a a vo i a a a a a she gvi tsqa i a len chve en



This work is licensed under a Creative Commons Attribution International 4.0 License. © 2024 Copyright held by Frank Scherbaum.

### Va Giorko (12TET)

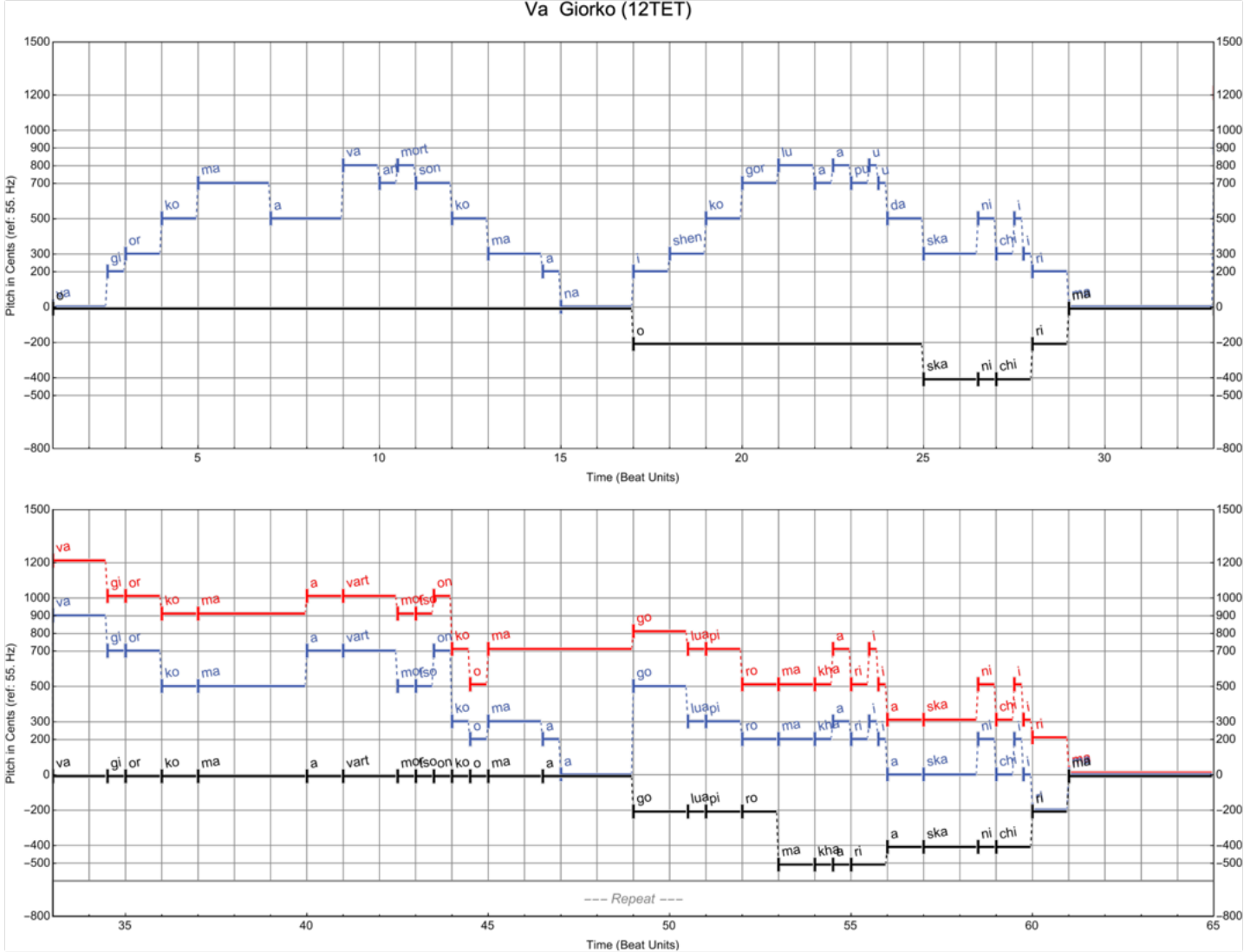

1. va gi or ko ma a va art mort son ko ma a a i shen ko gor lu a a pu u u da ska ni chi i i ri ma  
||: va gi or ko ma a vart mor tso on ko o ma a a go lua pi ro ma kha a ri i i a ska ni chi i i ri ma :||
2. u ska ne te ma a te ki i a na na a na ma pu sru li jo o khe e ti ska ni chi i i ri ma  
||: va gi or ko ma a vart mor tso on ko o ma a a go lua pi ro gu ri shi va a ar di ska ni chi i i ri ma:||



This work is licensed under a Creative Commons Attribution International 4.0 License. © 2024 Copyright held by Frank Scherbaum.

### Varado (12TET)

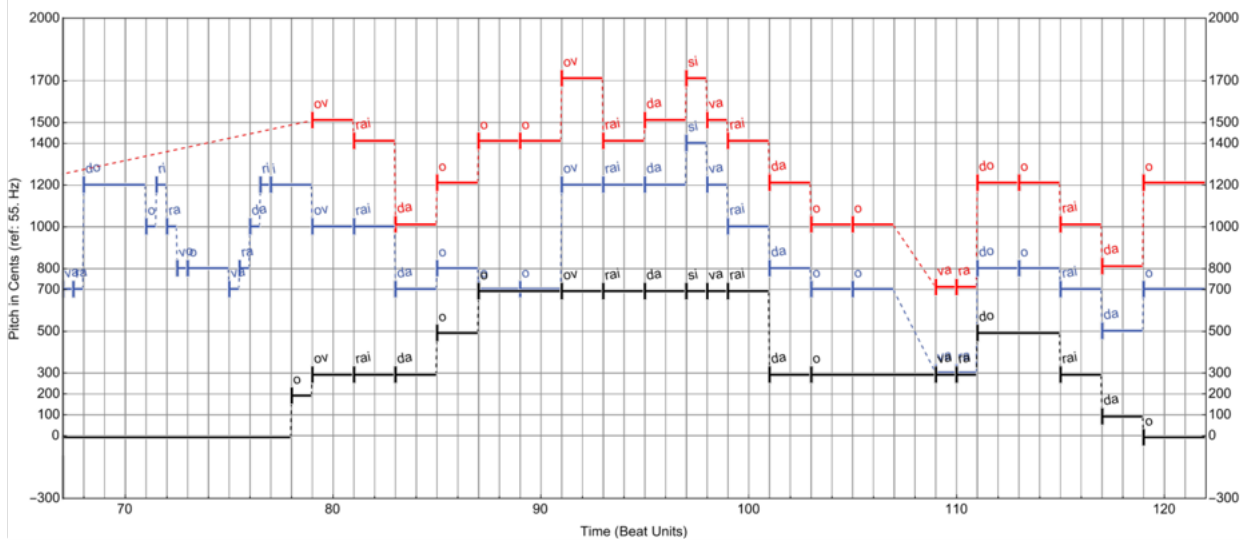
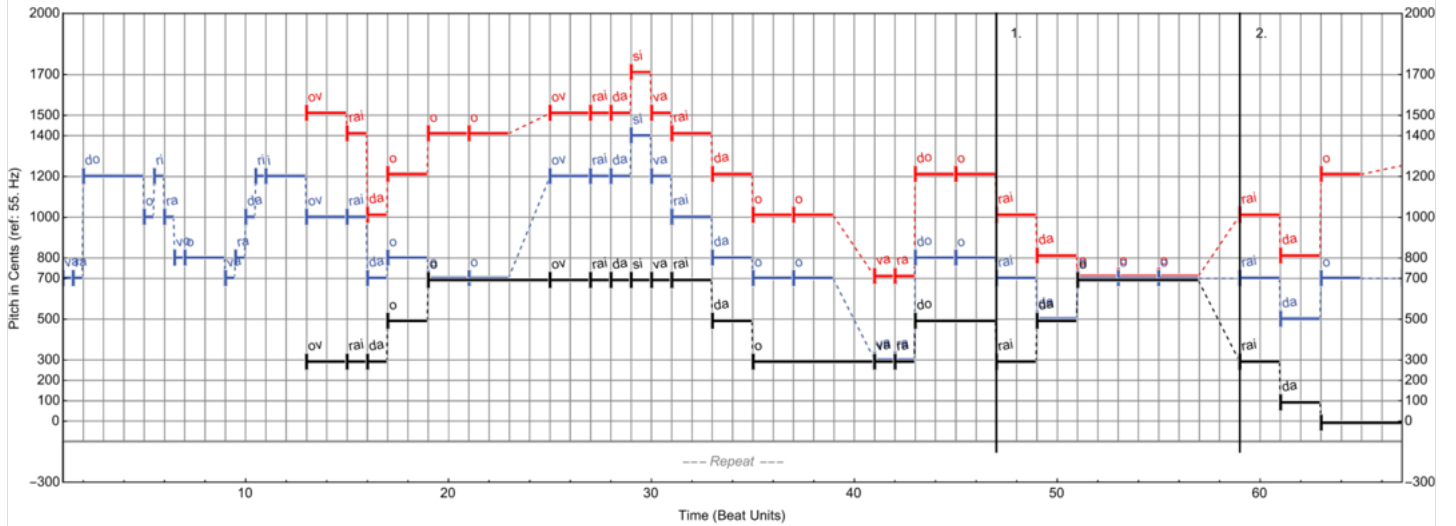

va ra do o ri ra vo o va ra da ri i ov rai da o o ov rai da si va rai da o o va ra do o rai da o o  
 va ra do o ri ra vo o va ra da ri i ov rai da o o ov rai da si va rai da o o va ra do o rai da o rai da o

### Zruni (12TET)

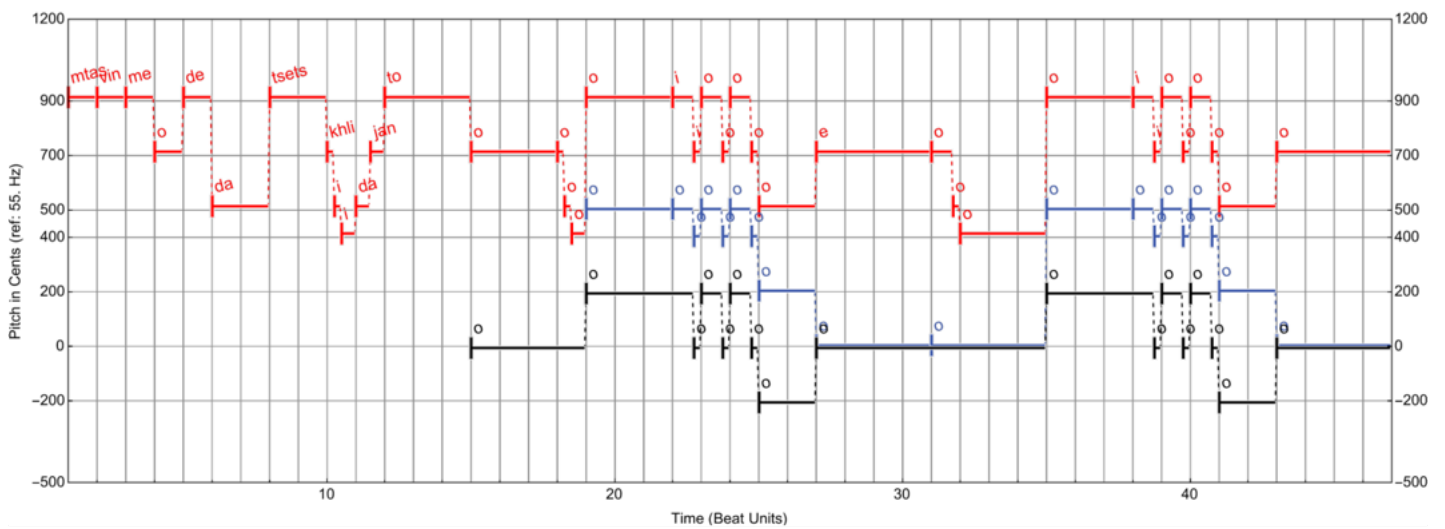

mtas vin me o de da tsets khli i i da jan to o o o o i i o o o o e o o o o i i o o o o o  
 tsets khli ta o de da da ja a a be di ta  
 chven mo na di re o de da a a gve go na  
 mas tur me o de da gu li i i stki o da



This work is licensed under a Creative Commons Attribution International 4.0 License. © 2024 Copyright held by Frank Scherbaum.